

Operator's Manual

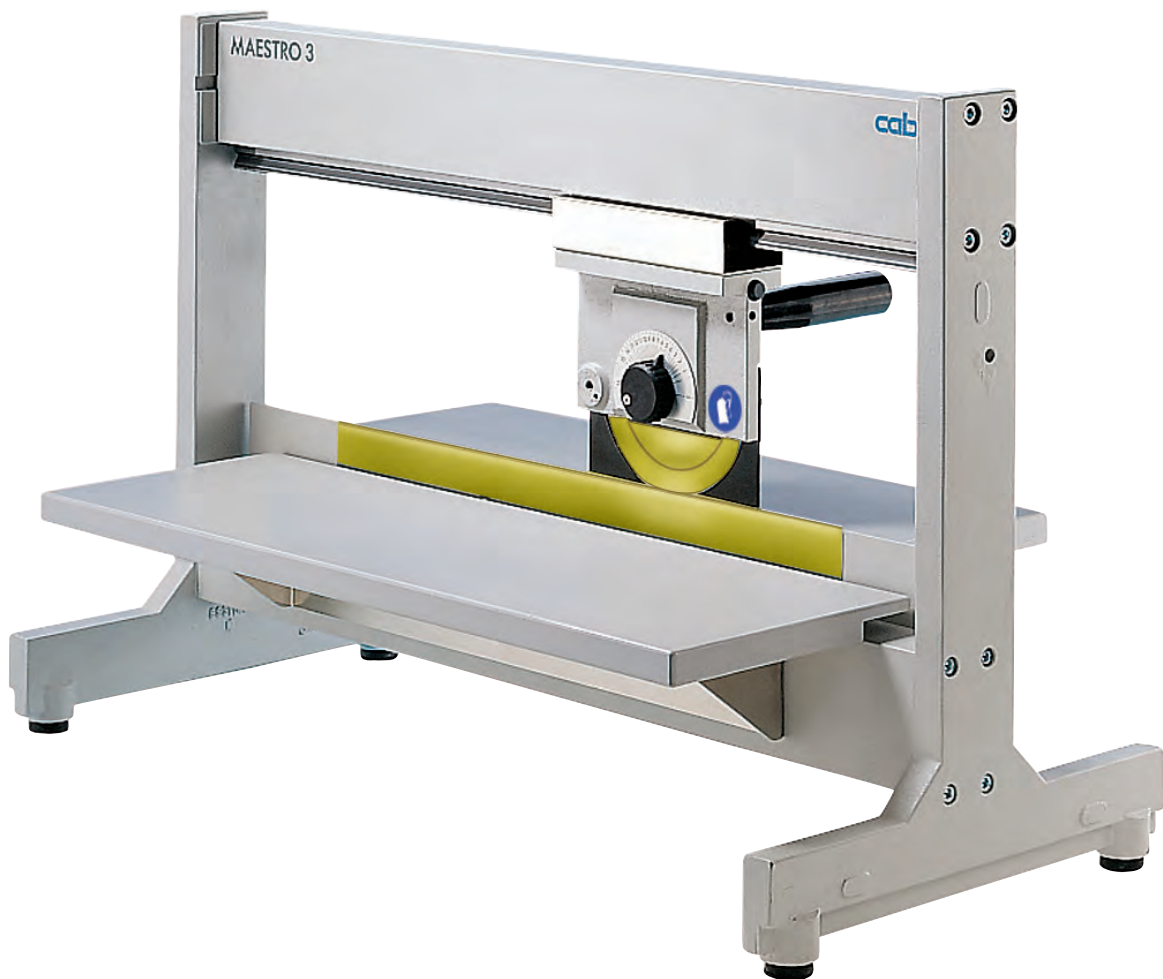

PCB Separator

MAESTRO 3E

for the following products

Family	Type
PCB Separator	MAESTRO 3E/450
PCB Separator	MAESTRO 3E/600

Edition: 05/2019 - Part No. 9008929

Copyright

This documentation as well as translation hereof are property of cab Produkttechnik GmbH & Co. KG.

The replication, conversion, duplication or divulgement of the whole manual or parts of it for other intentions than its original intended purpose demand the previous written authorization by cab.

Editor

Regarding questions or comments please contact cab Produkttechnik GmbH & Co. KG.

Topicality

Due to the constant further development of our products discrepancies between documentation and product can occur. Please check www.cab.de for the latest update.

Terms and conditions

Deliveries and performances are effected under the General conditions of sale of cab.

Germany
cab Produkttechnik GmbH & Co KG
 Karlsruhe
 Phone +49 721 6626 0
www.cab.de

USA
cab Technology, Inc.
 Chelmsford, MA
 Phone +1 978 250 8321
www.cab.de/us

Taiwan
cab Technology Co., Ltd.
 Taipei
 Phone +886 (02) 8227 3966
www.cab.de/tw

China
cab (Shanghai) Trading Co., Ltd.
 Guangzhou
 Phone +86 (020) 2831 7358
www.cab.de/cn

France
cab Technologies S.à.r.l.
 Niedermodern
 Phone +33 388 722501
www.cab.de/fr

Mexico
cab Technology, Inc.
 Juárez
 Phone +52 656 682 4301
www.cab.de/es

China
cab (Shanghai) Trading Co., Ltd.
 Shanghai
 Phone +86 (021) 6236 3161
www.cab.de/cn

South Africa
cab Technology (Pty) Ltd.
 Randburg
 Phone +27 11 886 3580
www.cab.de/za

1	Introduction	4
1.1	Instructions	4
1.2	Intended Use	4
1.3	Safety Instructions.....	4
1.4	Safety Marking	5
1.5	Environment.....	5
2	Specification.....	6
3	Installation	7
3.1	Unpacking and Setting-up the Device.....	7
3.2	Earthing Connection.....	7
3.3	Releasing the Upper Blade Lock.....	7
3.4	Height Adjustment of the Upper Blade	8
3.5	Adjustment of the Stop of the Upper Blade.....	9
3.6	Check the Blade Alignment	10
3.7	Upper Guide Adjustment.....	10
3.8	Adjustment of Table and Platform	11
4	Operation	11
5	Blade Replacement	12
5.1	Replacement Blades	12
5.2	Replacement of the Upper (Circular) Blade	12
5.3	Replacement of the Lower (Lineal) Blade	13
6	Index.....	14

1.1 Instructions

Important information and instructions in this documentation are designated as follows:

**Danger!**

Draws attention to an exceptionally great, imminent danger to your health or life due to hazardous voltages.

**Danger!**

Draws attention to a danger with high risk which, if not avoided, may result in death or serious injury.

**Warning!**

Draws attention to a danger with medium risk which, if not avoided, may result in death or serious injury.

**Caution!**

Draws attention to a danger with low risk which, if not avoided, may result in minor or moderate injury.

**Attention!**

Draws attention to potential risks of property damage or loss of quality.

**Note!**

Advices to make work routine easier or on important steps to be carried out.

**Environment!**

Gives you tips on protecting the environment.



Handling instruction



Reference to section, position, illustration number or document.



Option (accessories, peripheral equipment, special fittings).

1.2 Intended Use

- The device is manufactured in accordance with the current technological status and the recognized safety rules. However, danger to the life and limb of the user or third parties and/or damage to the device and other tangible assets can arise during use.
- The device may only be used for its intended purpose and if it is in perfect working order, and it must be used with regard to safety and dangers as stated in the operating manual.
- The device is intended exclusively for separating pre-scored PCB's. Any other use or use going beyond this shall be regarded as improper use. The manufacturer/supplier shall not be liable for damage resulting from unauthorized use; the user shall bear the risk alone.
- Usage for the intended purpose also includes complying with the operating manual, including the manufacturer's maintenance recommendations and specifications.

**Notice!**

The complete documentation can also currently be found in the Internet.

1.3 Safety Instructions

- Hazard by electrical charge. Provide an earthing connection via press stud.
- Risk of hand injury. Wear protective gloves while PCB separating.
- Ensure that people's clothing, hair, jewelry etc. do not come into contact with the exposed rotating blade.
- Work going beyond this may only be performed by trained personnel or service technicians.
- Unauthorized work on or modifications to the device can endanger operational safety.
- Always have service work done in a qualified workshop, where the personnel have the technical knowledge and

tools required to do the necessary work.

- There are various warning stickers on the device. They draw your attention to dangers. Warning stickers must therefore not be removed, as then you and other people cannot be aware of dangers and may be injured.

1.4 Safety Marking

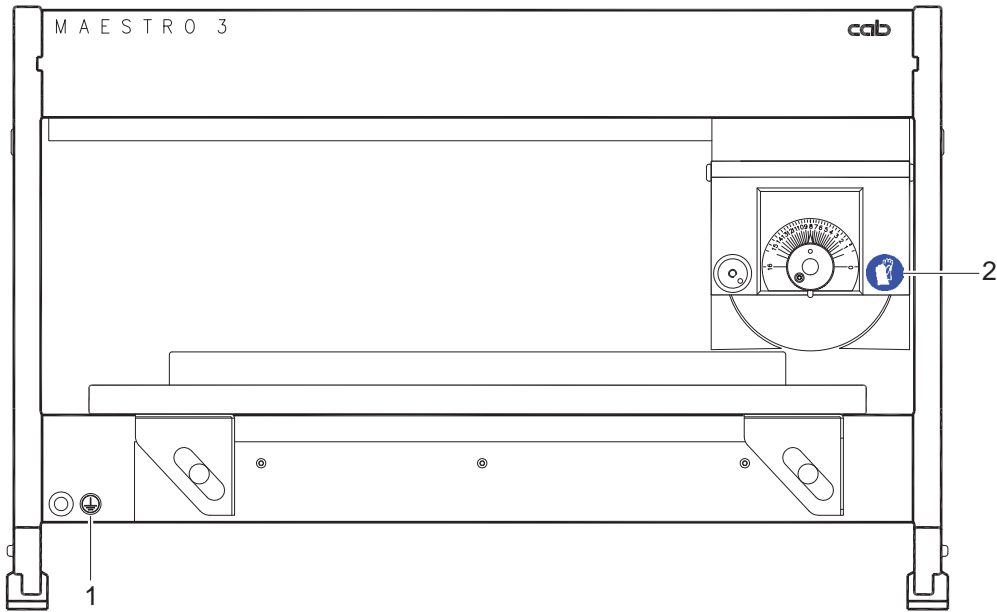

Fig. 1 Safety marking

1		<p>Hazard by electrical charge !</p> <p>▶ Provide an earthing connection via press stud.</p>
2		<p>Risk of hand injury !</p> <p>▶ Wear protective gloves while PCB separating.</p>

Table 1 Safety marking

1.5 Environment



Obsolete devices contain valuable recyclable materials that should be sent for recycling.

- ▶ Send to suitable collection points, separately from residual waste.

The modular construction of the printer enables it to be easily disassembled into its component parts.

- ▶ Send the parts for recycling.

For the commercially viable assembly and mounting of printed circuit boards, there is an ever increasing requirement for multiple-use material. The necessity however, to break off sections of the circuit board by hand can cause damage to the delicate circuitry and components. The fibre-glass material tears at the broken edge, leaving it rough and fissured.

Using the MAESTRO 3E, both large and small pre-scored PCB's can be cleanly and economically separated.

The circular blade is then drawn across the PCB thereby separating it into individual pieces. The scored grooves can be interrupted by any number of cut-outs.

Wear resistant blades and a guide assembly manufactured from special steel ensure maximum periods between readjustments.

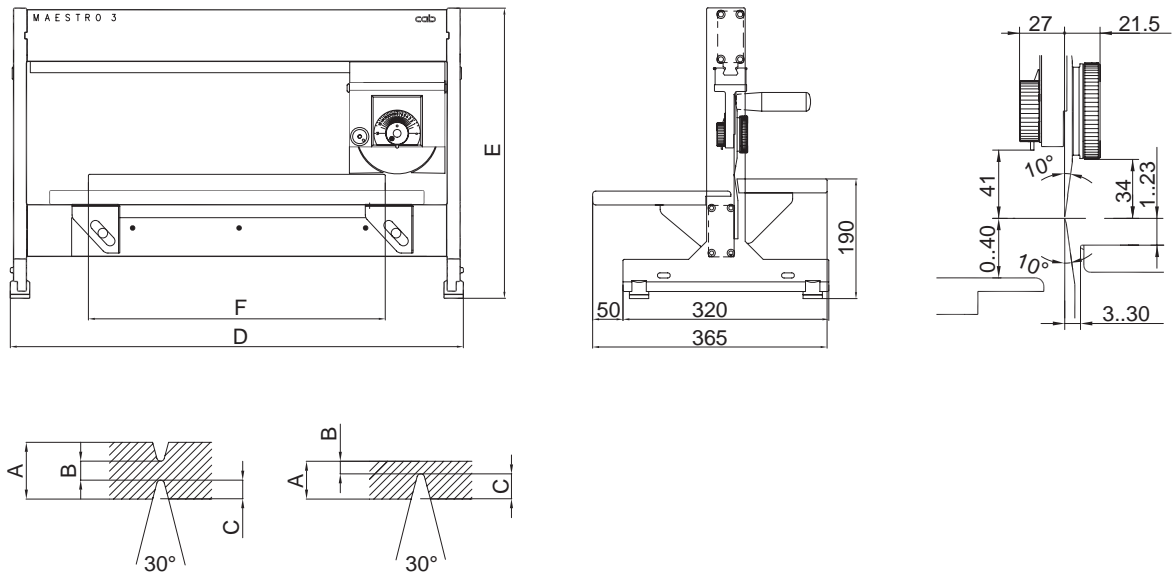

Fig. 2 Device and PCB dimensions

Technical Data		
Separation method		Component side: Circular blade Solder side: Linear blade
Operation		manual
Separation length		up to 450 mm
Material		FR4
Component height		Component side: up to 34 mm Solder side: up to 23 mm
Temperature / humidity not condensing	Operation	+10 – 35°C / 10–85%
	Stock	0 – 60°C / 20–80%
	Transport	-25 – 60°C / 20–80%
Width x Height x Depth		350 x 455 x 700 mm
Weight		22 kg
Approvals		CE, FCC Class A

Table 2 Technical Data

3.1 Unpacking and Setting-up the Device

- ▶ Lift the device out of the box.
- ▶ Check device for damage which may have occurred during transport.
- ▶ Set up device on a level surface.
- ▶ Check delivery for completeness.

Contents of delivery:

- PCB Separator
- Documentation
- Allen key 2 mm
- optional : Dial Gauge Assy. (Part No. 8970208) to check the alignment of the blades

Notice!



- ▶ Please keep the original packaging in case the device must be returned.

Attention!

The device and printing materials will be damaged by moisture and wetness.



- ▶ Set up the device only in dry locations protected from splash water.

3.2 Earthing Connection

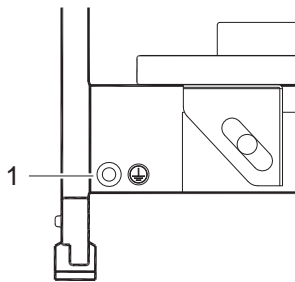

Fig. 3 Earthing Connection

Attention!

Hazard by electrical charge !



- ▶ Provide an earthing connection via press stud (1).

3.3 Releasing the Upper Blade Lock

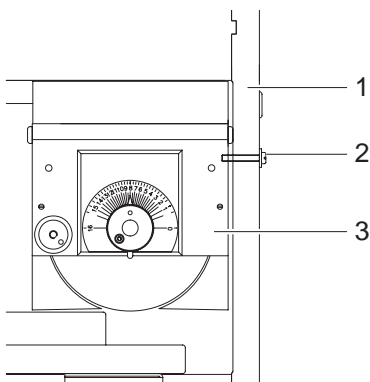

Fig. 4 Releasing the Upper Blade Lock

To avoid possible damage during transportation, the blade carrier (3) is fixed by a screw (2 / incl. washer) on the frame (1).

- ▶ Loosen the screw (2) before operation.

Warning!

Risk of injury !



- ▶ When moving the machine, or when it is to be dispatched elsewhere the screw (2) has to be tighten.

3.4 Height Adjustment of the Upper Blade

Notice!



To avoid possible damage on the blades during transport the upper blade (5) is fixed in the "Park Position" so that there is a maximum distance to the lower blade.

► Set the upper blade into the working position before starting operation.

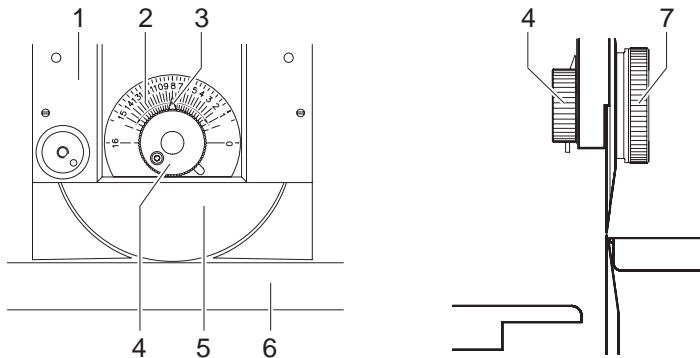

Fig. 5 Height adjustment of the upper blade

1. Move the blade carrier (1) to the approximate middle position over the lower blade (6).
There is a scale (2) on the upper blade carrier where you can see the height adjustment in steps of 1/10 mm. When you receive the machine, the pointer (3) of the scale is in position "16".
2. Hold the knob (4) and loosen the knurled knob (7).
4. Rotate the knob (4) clockwise until stop.
- Through that the upper blade (5) move down to the lower blade (6) until both blades are just touching one another (lower end position). Make a notice of the position of the pointer (3) to use it for all further adjustments. This lower end position locks the upper blade in place to prevent it from moving out of adjustment.
5. Move the knob (4) anti-clockwise until the pointer is in the middle position between the lower end position and the position "16".
6. Tighten the knurled knob (7).
7. Run some test-cuts to check if it is possible to separate the PCB's. If it is not possible reduce the distance between the blades in small steps.

Notice!



The described adjustment helps to reduce the separation forces. This is important when sensitive components are very close to the groove.

3.5 Adjustment of the Stop of the Upper Blade

Notice!

The lower stop of the upper blade adjustment is already adjusted by delivery.



► After a long operation time, while working at strongly varying temperatures or else after replacing a blade, it is recommended to re-adjust the lower stop.

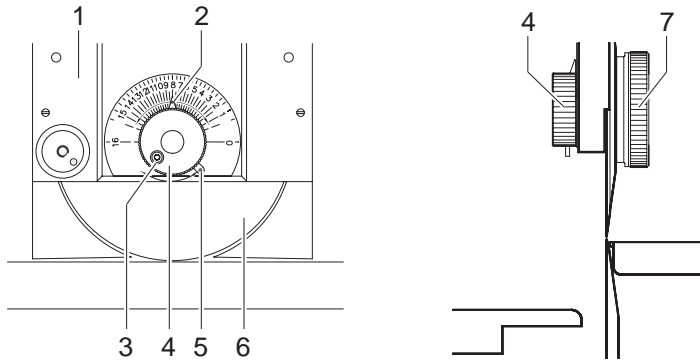

Fig. 6 Adjustment of the stop of the upper blade

1. Move the upper blade carrier (1) in the middle position of the lower blade.
2. Hold the knob (4) and loosen the knurled knob (7).
3. Rotate the pointer (2) with the knob (4) anti-clockwise into position "16".
4. Loosen the cylinder screw (3).
5. Move the knob (4) clockwise until the upper and lower blades gently touch without overlapping.
6. Hold tight the knob (4) and tighten the knurled knob (7).
7. Swing the strut (5) clockwise until you reach the stop and tighten the cylinder screw (3). This adjustment locks the upper blade in place to prevent it from moving out of adjustment.
8. Re-adjust the upper blade position ▷ 3.4 on page 8.

3.6 Check the Blade Alignment

Notice!



When the machine is put into operation for the first time, or following a move of equipment or a change of blades, it is advantageous to re-check the alignment of the blades in relationship to one another. For this purpose a dial gauge assembly (Part No. 8970208) is available as an option.

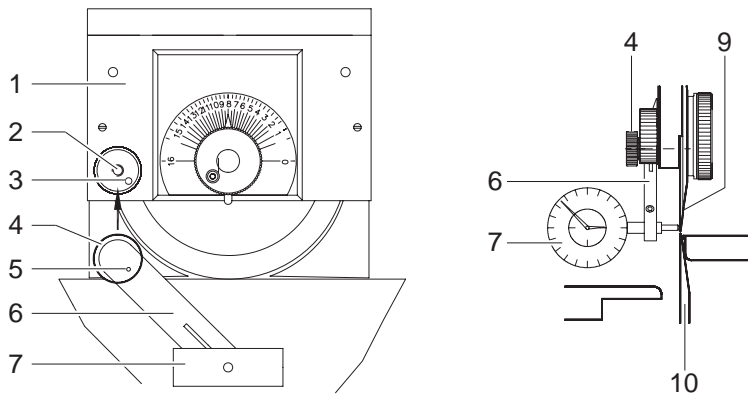

Fig. 7 Check the blade alignment

1. Move the blade carrier (1) to the middle of its range of travel.
2. Affix the dial gauge assembly onto the threaded hole (2) in the blade carrier and screw tight with the knurled screw (4) provided.
Ensure that the small spigot (5) mounted on the inside of the lever (6) locates correctly into the hole (3) provided in the blade carrier.
3. Swing the lever (6) upwards until the tip of the gauge feeler (7) presses onto the upper blade (9) at 2 mm of the edge of the blade. Rotate the scale on the dial gauge until the pointer in the 1/100 mm division is lined up with the „0“ on the scale.
4. Swing the lever (6) downwards until the tip of the gauge feeler (7) presses onto the lower blade (10) at 2 mm of the edge of the blade. The results achieved from measuring along the complete length of the lower blade may not vary by more than ± 0.1 mm from the values obtained from the upper blade measurements.
5. In the event of the values obtained by the above procedure being greater than ± 0.1 mm, the servicing agent responsible for your machine should be contacted.
6. Remove the dial gauge assembly.

3.7 Upper Guide Adjustment

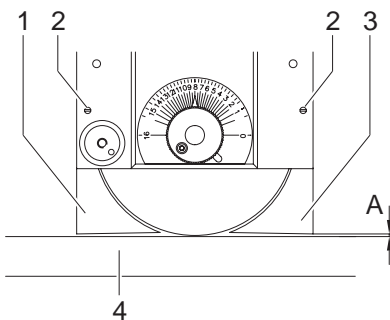

Fig. 8 Upper guide adjustment

1. Using a pre-scored PCB, check the clearance „A“ between the upper guides (1,3) and the lower blade (4). The clearance should be set so that the edge of the upper guide is located correctly into the pre-scored groove of the PCB. The PCB can be smoothly moved backwards and forwards but cannot move sideways.
The upper guides (1,3) prevent the PCB from slipping to the side and therefore ensures that it is not separated other than at the pre-scored groove.
2. As required, the clearance A should be adjusted as described above by turning the eccentric adjusters (2).

3.8 Adjustment of Table and Platform

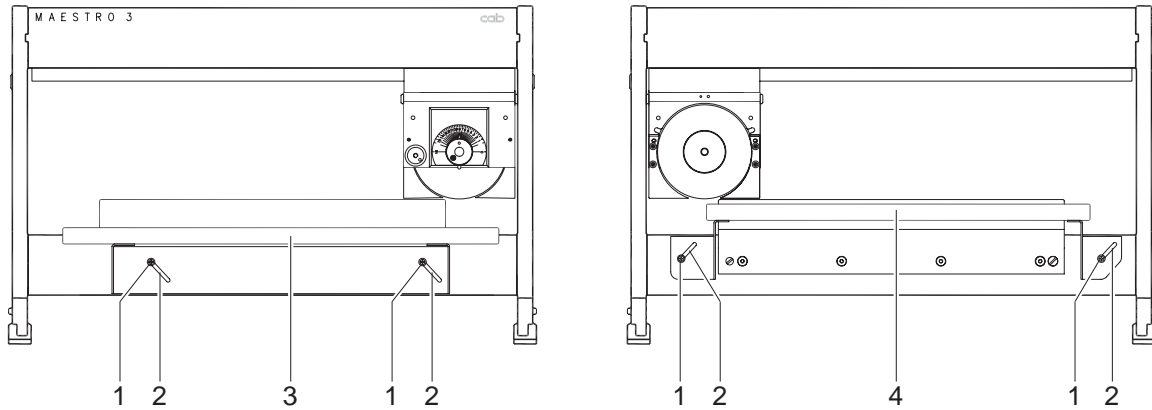

Fig. 9 Adjustment of Table and Platform

Adjust the height of table (3) and platform (4) as follows :

1. Loosen screws (1).
2. Move table (3) or platform (4) in the holes (2).
3. Tighten screws (1).

4 Operation



Warning!
Risk of hand injury !



► Wear protective gloves while PCB separating.



Notice!
When using the device for the first time, degrease the blades with a soft cloth.

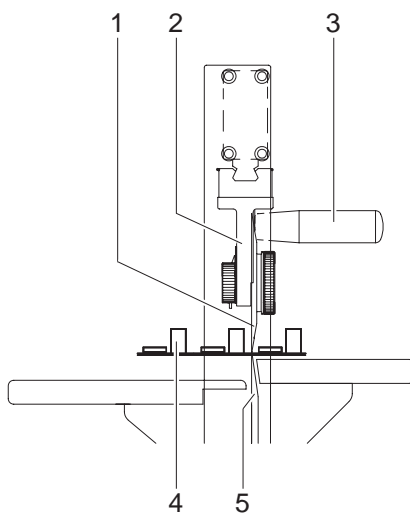

Fig. 10 Separating the PCB's

1. Move the blade carrier (2) to either the extreme front or rear end position.
2. Lay the PCB (4) onto the lower blade (5) so that the pre-scored groove in the PCB locates onto the blade edge. The PCB is held in the horizontal position by hand.
3. To separate the PCB, the blade carrier with the upper blade (1) is drawn or pushed across the PCB with the handle (3).

5.1 Replacement Blades

Type		Circular Blade		Lineal Blade	
Part No.	Description	Part No.	Description	Part No.	Description
8933945	MAESTRO 3E/450	8930509.001	Circular Blade	8933394.001	Lineal Blade 450/370
8935000	MAESTRO 3E/600	8930509.001	Circular Blade	8933682.001	Lineal Blade 600/520

Table 4 Replacement Blades

5.2 Replacement of the Upper (Circular) Blade



Warning!
Risk of hand injury !



► Wear protective gloves while handling the blades.

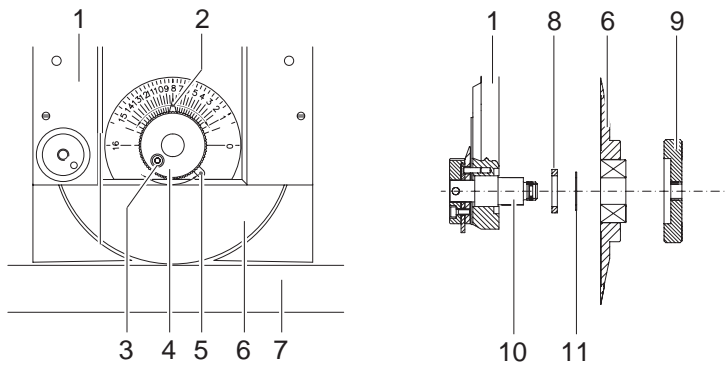

Fig. 11 Replacement of the upper blade

- Loosen the knurled knob (9) completely from the blade shaft (10).
- Rotate the pointer (2) with the knob (4) anti-clockwise into position "16".
- Remove the circular blade (6) from the blade shaft (10).
Do not lose the spacers (8,11) located on the blade shaft (10), between the blade (6) and the carrier (1).
Replace the spacers (8,11) if necessary.
- Slide the replacement blade (6) onto the blade shaft as far as possible.
- Put the knurled knob (9) onto the blade shaft.
- Move the blade carrier (1) to the center of the lower blade (7).
- Loosen the cylinder screw (3).
- Move the knob (4) clockwise until the upper and lower blade gently touch without overlapping.
- Swing the strut (5) clockwise until you reach the stop and tighten the cylinder screw (3). This adjustment locks the upper blade in place to prevent it from moving out of adjustment.
- Adjust the upper blade position ► 3.4 on page 8.
- Tighten the knurled knob (9).
- In the event of the optional dial gauge assembly being available, check the alignment of the blades
► 3.6 on page 10.

5.3 Replacement of the Lower (Lineal) Blade



Warning!
Risk of hand injury !



► Wear protective gloves while handling the blades.

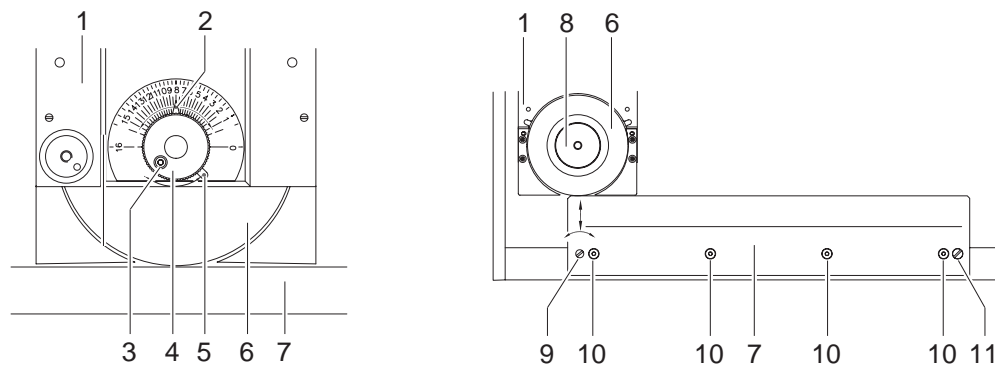

Fig. 12 Replacement of the lower blade

1. Move the blade carrier (1) to the end of the lower blade (7) above the eccentric adjuster (9).
2. Loosen the cylinder screws (10).
3. Move the lower blade (7) fully downwards by carefully rotating the eccentric adjuster (9).
4. Loosen the set-screw (11) and remove the lower blade (7) from the eccentric adjuster (9).
5. Mount the new lower blade (7) onto the eccentric adjuster (9) and reinsert the set-screw (11) into the machine frame.
6. Tighten loosely the cylinder screws (10).
7. Loosen the knurled knob (8) on the upper blade (6) and move the pointer (2) with knob (4) anti-clockwise into position "16".
8. Move the carrier (1) to the end of the lower blade (7) above the locking screw (11).
9. Loosen the cylinder screw (3).
10. Rotate the knob (4) clockwise until the upper and lower blades gently touch without overlapping.
11. Swing the strut (5) clockwise until you reach the stop and tighten the cylinder screw (3). This adjustment locks the upper blade (6) in place to prevent it from moving out of adjustment.
12. Tighten the knurled knob (8).
13. Move the blade carrier (1) to the other end of the lower blade (7) above the eccentric adjuster (9).
14. Raise the lower blade by carefully rotating the eccentric adjuster (9) until the upper and lower blades are just touching one another at this position, but do not jam.
15. Tighten the cylinder screws (10).
16. Adjust the upper blade position ► 3.4 on page 8.
17. In the event of the optional dial gauge assembly being available, check the alignment of the blades
► 3.6 on page 10.

B

Blade alignment..... 10

C

Circular blade 12

Contents of delivery..... 7

D

Dial gauge assembly 10

E

Earthing 7

I

Important information..... 4

Intended use..... 4

L

Lineal blade 12, 13

Lower blade

 Replacement..... 13

P

Platform 11

Protective gloves 11, 12

R

Recycling 5

Replacement blades..... 12

S

Safety instructions 4

Separation forces 8

Service work..... 4

Setting-up 7

Specification 6

T

Table 11

Technical data..... 6

U

Unpacking..... 7

Upper blade

 Adjustment..... 8

 Replacement..... 12

 Stop 9

Upper guides 10

W

Warning stickers 4