

## Assembly Instructions



Stroke-Blow Applicator

# HQ 4614

## 2 Assembly Instructions for the following products

2

Family	Type
Stroke-Blow Applicator	HQ 4614-200L
	HQ 4614-300L
	HQ 4614-400L
	HQ 4614-200R
	HQ 4614-300R
	HQ 4614-400R

**Edition:** 06/2026 - **Part No.** 9004081

### Copyright

This documentation as well as translation hereof are property of cab Produkttechnik GmbH & Co. KG.

The replication, conversion, duplication or divulgement of the whole manual or parts of it for other intentions than its original intended purpose demand the previous written authorization by cab.

### Editor

Regarding questions or comments please contact cab Produkttechnik GmbH & Co. KG.

### Topicality

Due to the constant further development of our products discrepancies between documentation and product can occur. Please check [www.cab.de](http://www.cab.de) for the latest update.

### Terms and conditions

Deliveries and performances are effected under the General conditions of sale of cab.

---

Germany  
**cab Produkttechnik GmbH & Co KG**  
Karlsruhe  
Phone +49 721 6626 0  
[www.cab.de](http://www.cab.de)

USA  
**cab Technology, Inc.**  
Chelmsford, MA  
Phone +1 978 250 8321  
[www.cab.de/us](http://www.cab.de/us)

Taiwan  
**cab Technology Co., Ltd.**  
Taipei  
Phone +886 (02) 8227 3966  
[www.cab.de/tw](http://www.cab.de/tw)

Singapore  
**cab Singapore Pte. Ltd.**  
Singapore  
Phone +65 6931 9099  
[www.cab.de/en](http://www.cab.de/en)

France  
**cab Technologies S.à.r.l.**  
Niedermodern  
Phone +33 388 722501  
[www.cab.de/fr](http://www.cab.de/fr)

Mexico  
**cab Technology, Inc.**  
Juárez  
Phone +52 656 682 4301  
[www.cab.de/es](http://www.cab.de/es)

China  
**cab (Shanghai) Trading Co., Ltd.**  
Shanghai  
Phone +86 (021) 6236 3161  
[www.cab.de/cn](http://www.cab.de/cn)

South Africa  
**cab Technology (Pty) Ltd.**  
Randburg  
Phone +27 11 886 3580  
[www.cab.de/za](http://www.cab.de/za)

<b>1</b>	<b>Introduction .....</b>	<b>4</b>
1.1	Instructions.....	4
1.2	Intended Use.....	4
1.3	Safety Instructions.....	4
1.4	Safety Markings .....	5
1.5	Environment.....	5
<b>2</b>	<b>Product Description.....</b>	<b>6</b>
2.1	Important Features.....	6
2.2	Technical Data.....	6
2.3	Product Overview.....	7
2.4	Contents of Delivery.....	8
<b>3</b>	<b>Mounting.....</b>	<b>9</b>
<b>4</b>	<b>Operation .....</b>	<b>10</b>
4.1	Standard Operation.....	10
4.2	Cleaning.....	10
<b>5</b>	<b>Error Messages .....</b>	<b>11</b>
5.1	Error Messages of the Printer .....	11
5.2	Error messages of the applicator .....	11
<b>6</b>	<b>Licences.....</b>	<b>12</b>
6.1	Declaration of Incorporation.....	12
6.2	EU Declaration of Conformity.....	13

## 1.1 Instructions

Important information and instructions in this documentation are designated as follows:



### Danger!

Draws attention to an exceptionally great, imminent danger to your health or life due to hazardous voltages.



### Danger!

Draws attention to a danger with high risk which, if not avoided, may result in death or serious injury.



### Warning!

Draws attention to a danger with medium risk which, if not avoided, may result in death or serious injury.



### Caution!

Draws attention to a danger with low risk which, if not avoided, may result in minor or moderate injury.



### Attention!

Draws attention to potential risks of property damage or loss of quality.



### Note!

Advice to make work routine easier or on important steps to be carried out.



### Environment!

Gives you tips on protecting the environment.



Handling instruction.



Reference to section, position, illustration number or document.



Option (accessories, peripheral equipment, special fittings).

*Time*

Information in the display.

## 1.2 Intended Use

- The device is manufactured in accordance with the current technological status and the recognized safety rules. However, danger to life and limb of the user or third parties and/or damage to the device and other tangible assets can arise during use.
- The device may only be used for its intended purpose and if it is in perfect working order, and it must be used with regard to safety and dangers as stated in the manual.
- The device is designed to use on a cab printer of the HERMES Q series. Any other use or use going beyond this shall be regarded as improper use. The manufacturer/supplier shall not be liable for damage resulting from unauthorized use; the user shall bear the risk alone.
- Usage for the intended purpose also includes complying with the manual.



### Note!

The complete and current version of the documentation can be found in the Internet.

## 1.3 Safety Instructions



### Attention!

Initiation, adjustments and changing of parts are to be performed by qualified service personnel only.



### Warning!

This is a class A product. In a domestic environment this product may cause radio interference in which case the user may be required to take adequate measures.

- Before mounting the delivered components disconnect the printer from the power supply and close the shutoff valve of the applicator.
- Only connect the device to other devices which have a protective low voltage.
- Switch off all affected devices (computer, printer, accessories) before connecting or disconnecting.
- In operation, moving parts are easily accessible.  
This applies especially for the zone, where the pad is moved between the starting and the labelling position. During operation do not reach into that zone and keep long hair, loose clothes, and jewelry distant. Before any manipulations in those areas, close the shutoff valve.
- The device may only be used in a dry environment, do not expose it to moisture (sprays of water, mists, etc.).
- Do not use the device in an explosive atmosphere.
- Do not use the device close to high-voltage power lines.
- Perform only those actions described in this manual.  
Work going beyond this may only be performed by trained personnel or service technicians.
- Unauthorized interference with electronic modules or their software can cause malfunctions.
- Other unauthorized work on or modifications to the device can also endanger operational safety.
- Always have service work done in a qualified workshop, where the personnel have the technical knowledge and tools required to do the necessary work.
- There are various warning stickers on the device. They draw your attention to dangers. Warning stickers must therefore not be removed, as then you and other people cannot be aware of dangers and may be injured.

1.4 Safety Markings

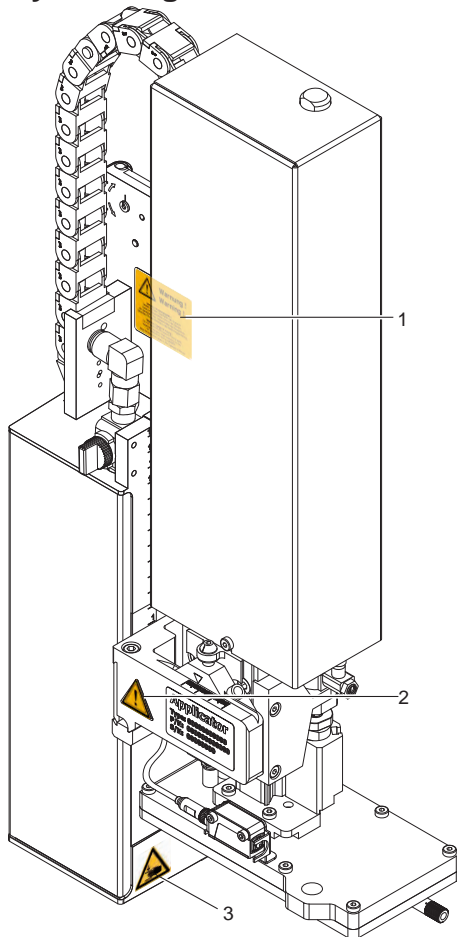

1: Risk of injuries by moving parts!



2: The cylinder is under pressure also if the printer is switched off. Possibility of residue energy!



3: Danger of crushing hands and fingers by the moving pad!



**Attention!**  
Never remove or cover safety markings!  
Replace it in case of damage!



Fig. 1 Safety marking

1.5 Environment



Obsolete devices contain valuable recyclable materials that should be sent for recycling.

- ▶ Send to suitable collection points, separately from residual waste.  
The modular construction of the print module enables it to be easily disassembled into its component parts.
- ▶ Send the parts for recycling.

## 2.1 Important Features

- The supporting air, the vacuum as well as the speed of the cylinder are adjustable. That way the applicator can be adapted to different label materials and sizes.
- To avoid contamination within the vacuum channels they are cleaned by air pressure pulses at the end of each application.
- For operation in a system the I/O interface of the printer can be used.

## 2.2 Technical Data

Stroke blow applicator		HQ 4614 L/R-200	HQ 4614 L/R-300	HQ 4614 L/R-400
Distance of a package to the bottom of the unit	up to mm	140	240	340
Package heights	variable	■		
Label applications		from the top, from below, from the side		
State of a package at the moment a label is applied	at rest in motion	■ ■	■ ■	■ ■
Weight of applicator	packaging excluded kg	n.a.	5.5	6.5
Consumption of power	W max.		15	
Compressed air	bar		4.5	
Cycle rate <sup>1)</sup>	labels/min approx.		25	

<sup>1)</sup> calculated using a stroke of 100 mm below the unit, labels 100 mm high, a print speed of 100 mm/s

Blow-on pad			4614L/R-2100 B x H
Label widths	HERMES Q4/Q4.3	mm	20 - 114
	HERMES Q6.3	mm	provided upon request
Label heights	HERMES Q4/Q4.3	mm	20 - 100
	HERMES Q6.3	mm	provided upon request

Table 1 Technical Data

2.3 Product Overview

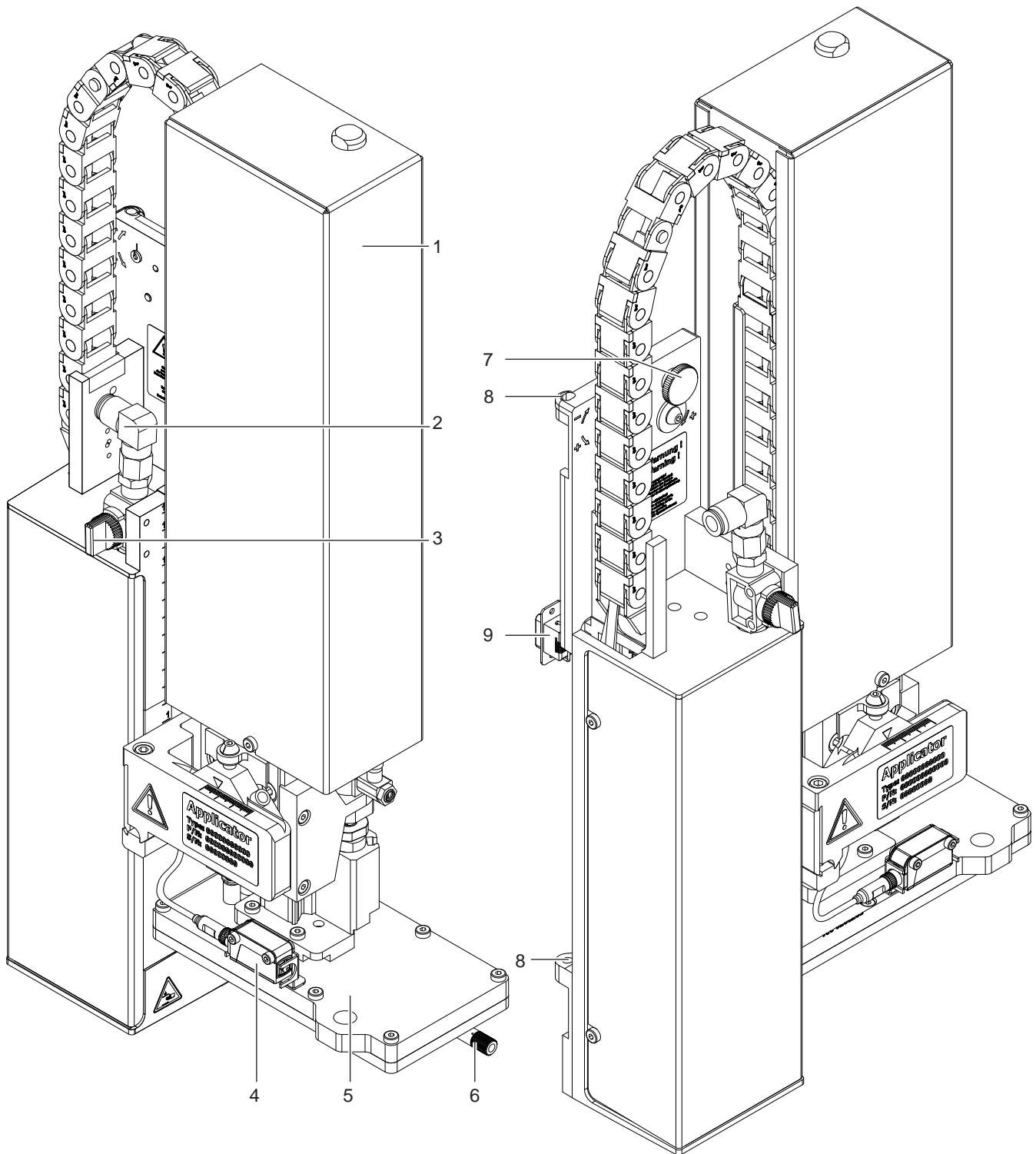
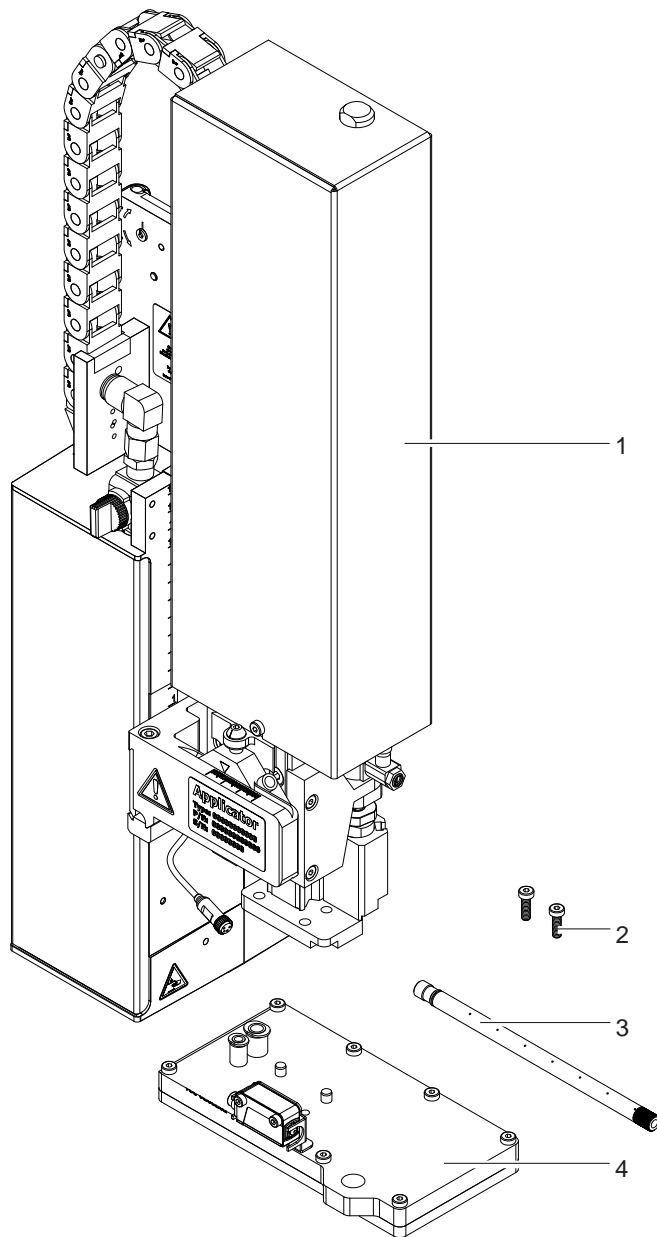

Fig. 2 Device overview

- |   |                          |   |   |
|---|--------------------------|---|---|
| 1 | Cover                    | 6 | Blow tube for supporting air                              |
| 2 | Compressed air connector | 7 | Knurled screw for attaching the applicator to the printer |
| 3 | Shutoff valve            | 8 | Hinges  |
| 4 | Product sensor           | 9 | SUB-D 15 Interface to the printer                         |
| 5 | Pad (customized)         |   |   |

## 2.4 Contents of Delivery



- Applicator (1)
- Screws (part of the pad) (2)
- Blow tube (as ordered) (3)
- Pad (as ordered) (4)
- Documentation

Fig. 3 Contents of delivery

**Note!**

Please keep the original packaging in case the applicator must be returned.

**Attention!**

The device and printing materials will be damaged by moisture and wetness.

- ▶ Set up label printer with applicator only in dry locations protected from splash water.

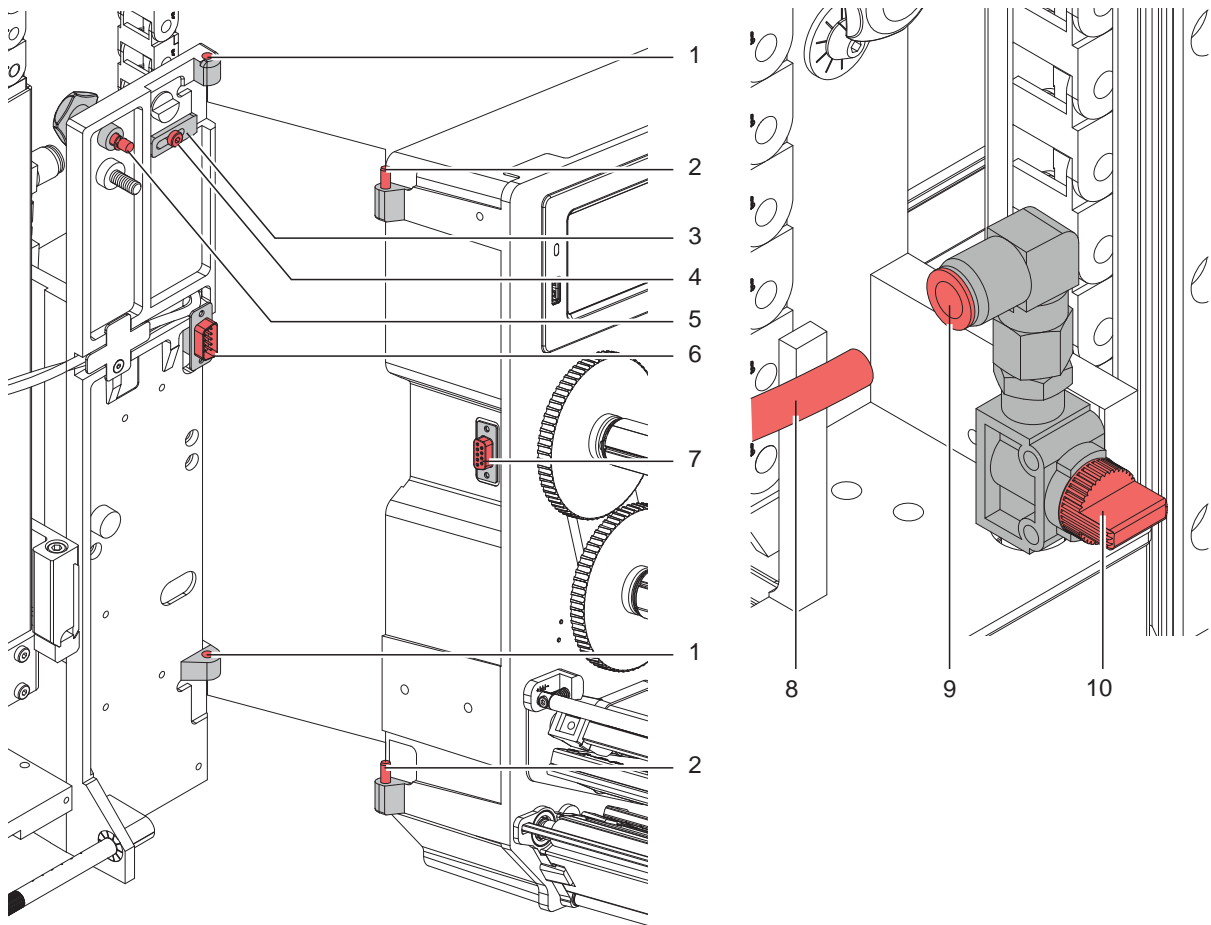

Fig. 4 Mounting applicator on printer



### Attention!

Initiation, adjustments and changing of parts is only for qualified service personal only.

▷ Service Manual

#### Mount the applicator

1. Hang the applicator with the female part of hinges (1) at the printer mounted hinges parts (2).
2. Connect SUB-D 15 male connector (6) to the female connector (7) of the printer.
3. To prevent the applicator from slipping out of the hinges loosen screw (4) and move the locking plate (3) under the hinges and tighten screw (4).
4. Swing the applicator to the printer and tighten the thumbscrew (5).
5. Keep the external compressed air supply closed and close the shut-off valve (10) on the applicator ▷ see illustration
6. Insert external compressed air supply (8) into the plug connector (9) on the shut-off valve (10).
7. Switch on compressed air and open shut-off valve (10) by turning 90 °.

For cleaning the applicator and printer it's sometime necessary to turn away or/and dismount the applicator. Don't change the adjustments of setting screws, throttle valves or other.

#### Turn away/Dismount the applicator

8. To turn away the applicator loosen thumbscrew (5) and swing the applicator aside.
9. Disconnect SUB-D 15 male connector (6) to the female connector (7) of the printer.
10. Loosen screw (4) and move off the locking plate (3) from the hinges.
11. Lift the applicator upward.

### 3.1 Mounting and Dismounting the Cover

To initiate the applicator or for adjustments it is necessary to dismount the cover (2). After these adjustments have been completed remount the cover.



#### Warning!

- ▶ Do not operate the applicator without cover (2).
- ▶ Only dismount the cover when servicing the applicator.

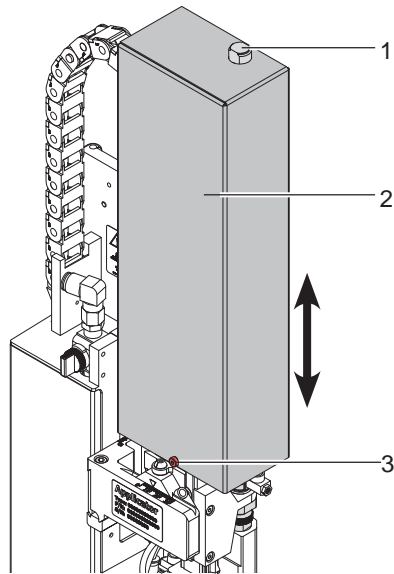

#### Dismount

1. Loosen screw (3).
2. Lift off cover (2).

#### Mount

3. Move the cover (2) over the cylinder assembly.
4. Put in the cylinder (1) through the hole in the cover (2).
5. Tighten screw (3) to fasten the cover (2).

Fig. 5 Cover

### 3.2 Transportation Lock

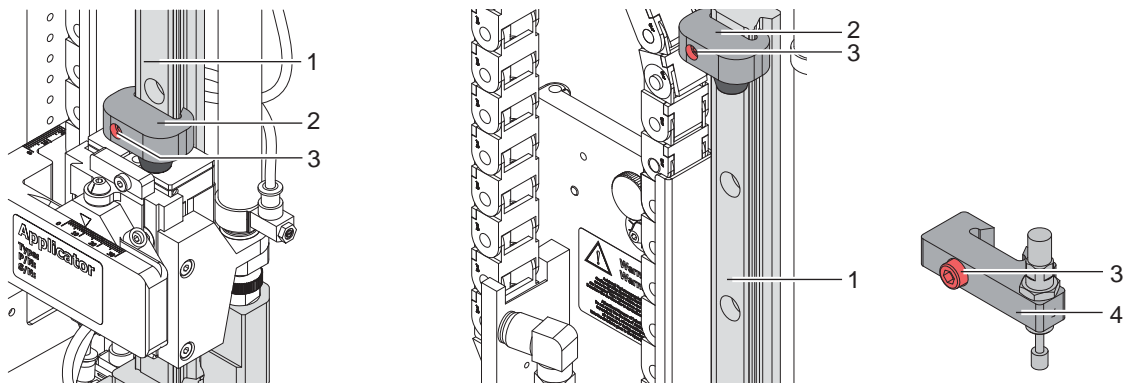

Fig. 6 Stopper as transportation lock

When the applicator is delivered, the stopper (2) is mounted on the rod (1). With this stopper (2) the labelling position for the operation mode "Blow on" can be adjusted. In delivery status the stopper (2) is used as transportation lock.



#### Note!

To reduce the impact energy it is possible to use a stopper with cushioning (4).

#### Releasing the transportation lock

1. Loosen screw (3) of the stopper (2).
2. Move the stopper (2) along the rod (1) into the position as in operation mode:
  - *Transfer mode: Blow on*  
Position the stopper(2) so that the stamp is approximately 5-10 mm away from the product and push the stop towards the stamp on the slide.
  - *Transfer mode: Stamp on*  
Move the stopper (2) up to the end of the rod (1).
3. Tighten screw (3) to fix the stopper (2) in position.

3.3 Mounting the Blow Tube

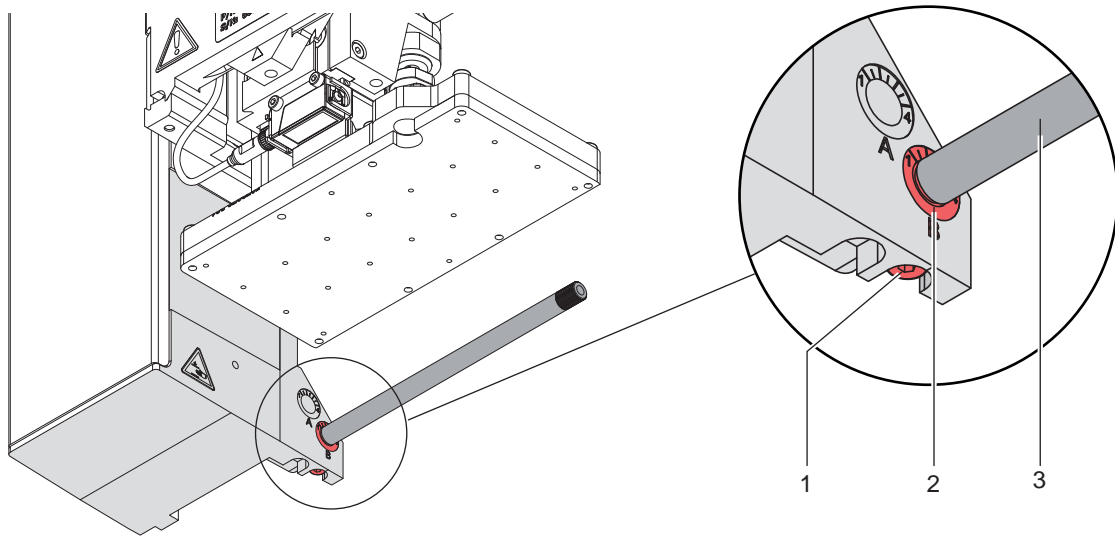
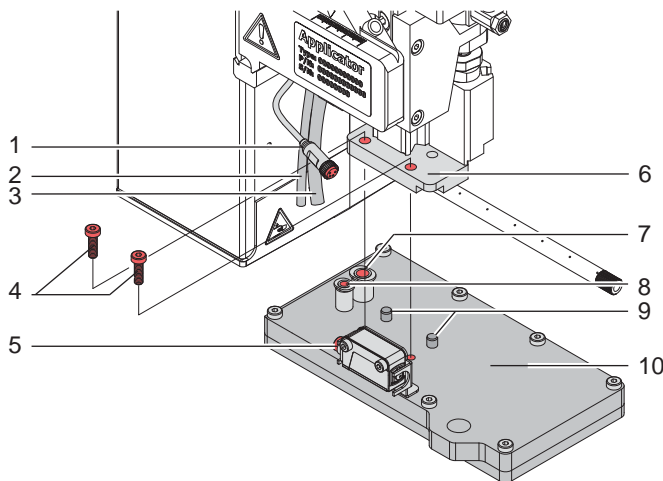

Fig. 7 Mounting the blow tube

It is possible to rotate the blow tube to optimize the support air for the take over procedure of the label from printer to applicator.

1. Loosen screw (1).
2. Put in the blow tube (3) into the blow tube hole B (2).
3. Tighten screw (1) lightly to secure it.

3.4 Mounting the Pad



4. Insert the two pins (9) on the pad (10) into the holes on the bottom of the pad holder (6).
5. Fix the pad (10) with the screws (4) to the pad holder (6).
6. Insert the vacuum tube (2) and the support air tube (3) into the appropriate push-in-fittings (7, 8) of the pad.
7. Insert the connector (1) into the female connector (5) of the product sensor and tighten the nut.

Fig. 8 Mounting the pad



**Attention!**

► To avoid possible collisions of the pad with other parts of the printer-applicator system, please roughly align the pad in all directions (▷ „3.5 Adjusting the Pad“ on page 12 before connecting the applicator to the compressed air supply!

### 3.5 Adjusting the Pad

For the perfect application of labels it is necessary that the pad is placed precisely above the dispensed label.

#### Aligning the pad parallel to the dispensing plate

The edge of the pad should be positioned parallel to the dispensing plate of the printer in order to position the label exactly on the pad.

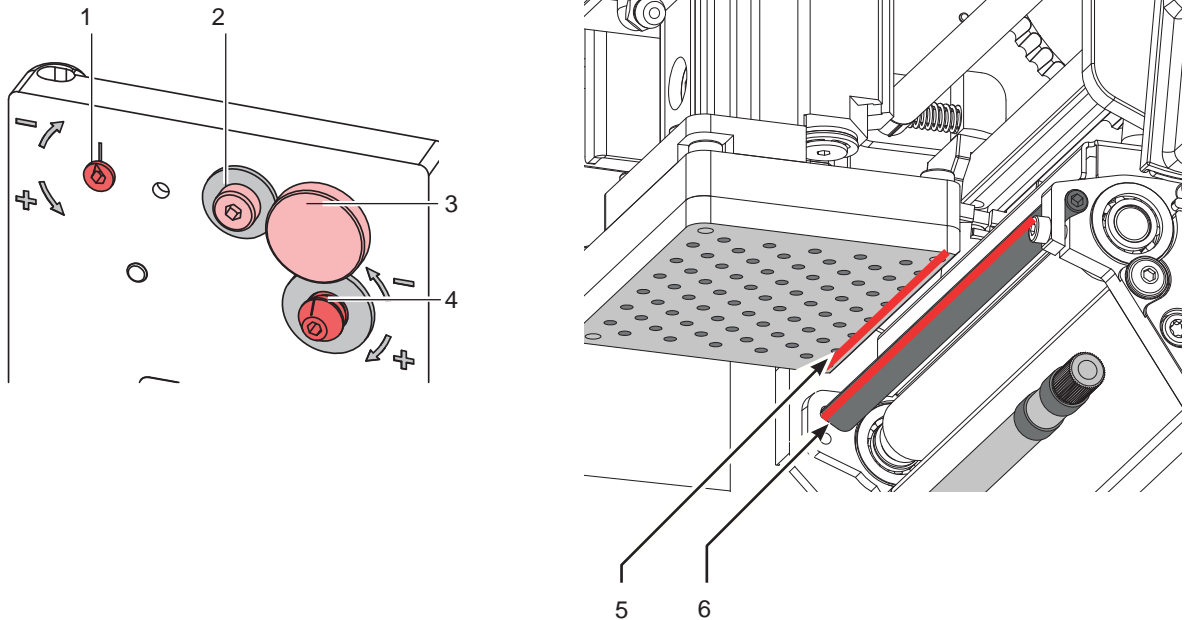
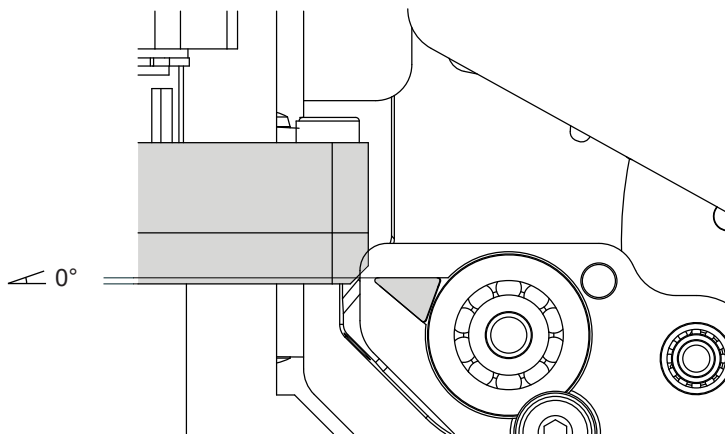

Fig. 9 Aligning the pad to the dispensing plate

1. Loosen the knurled screw (3) and the set screw (4).
2. Screw in the knurled screw (3) until the pad edges (5) are aligned parallel to the dispensing edge (6) of the printer.
3. Tighten the set screw (4) until it touches the printer.

#### Aligning the pad at an angle to the dispensing plate



4. If the angle between the pad surface and the dispensing edge - support surface is not  $0^\circ$  loosen screw (2).
5. Correct the angle of attack by turning the eccentric (1).
6. Tighten screw (2).

3.5.1 Moving the Pad in Y-Direction

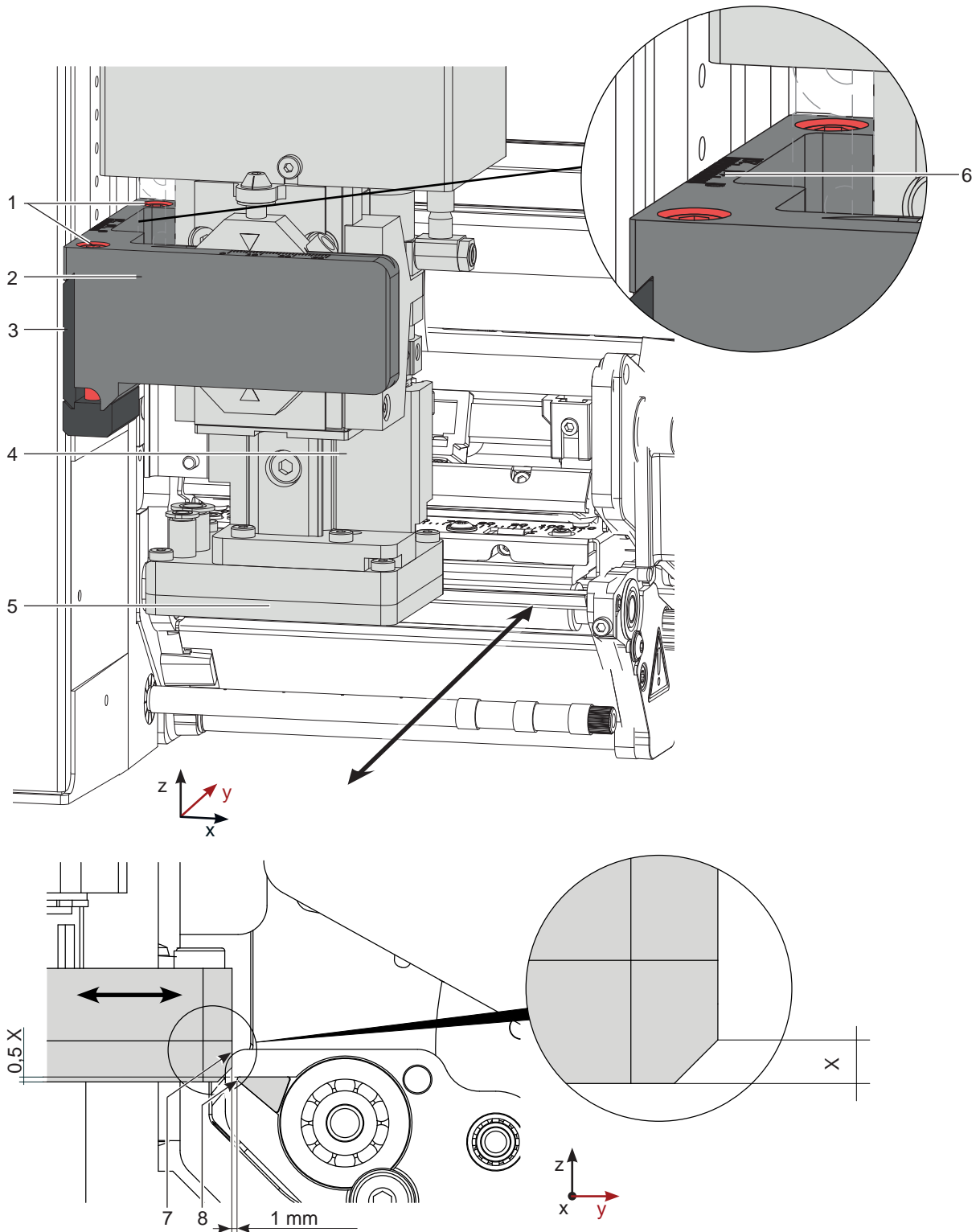

Fig. 10 Displacement in the Y direction

**Displacement in the Y direction (printing direction)**

1. Loosen screws (1) on the cross beam (2).
2. Move cylinder assembly (4) with the pad (5) and crossbeam (2) along the guiding rail (3) that the distance from the edge of the pad (7) to the edge of the dispensing plate (8) of the printer is approximately 1 mm.  
Orientation: Graduation (6)
3. Tighten screws (1).

## 3.5.2 Moving the Pad in Z-Direction

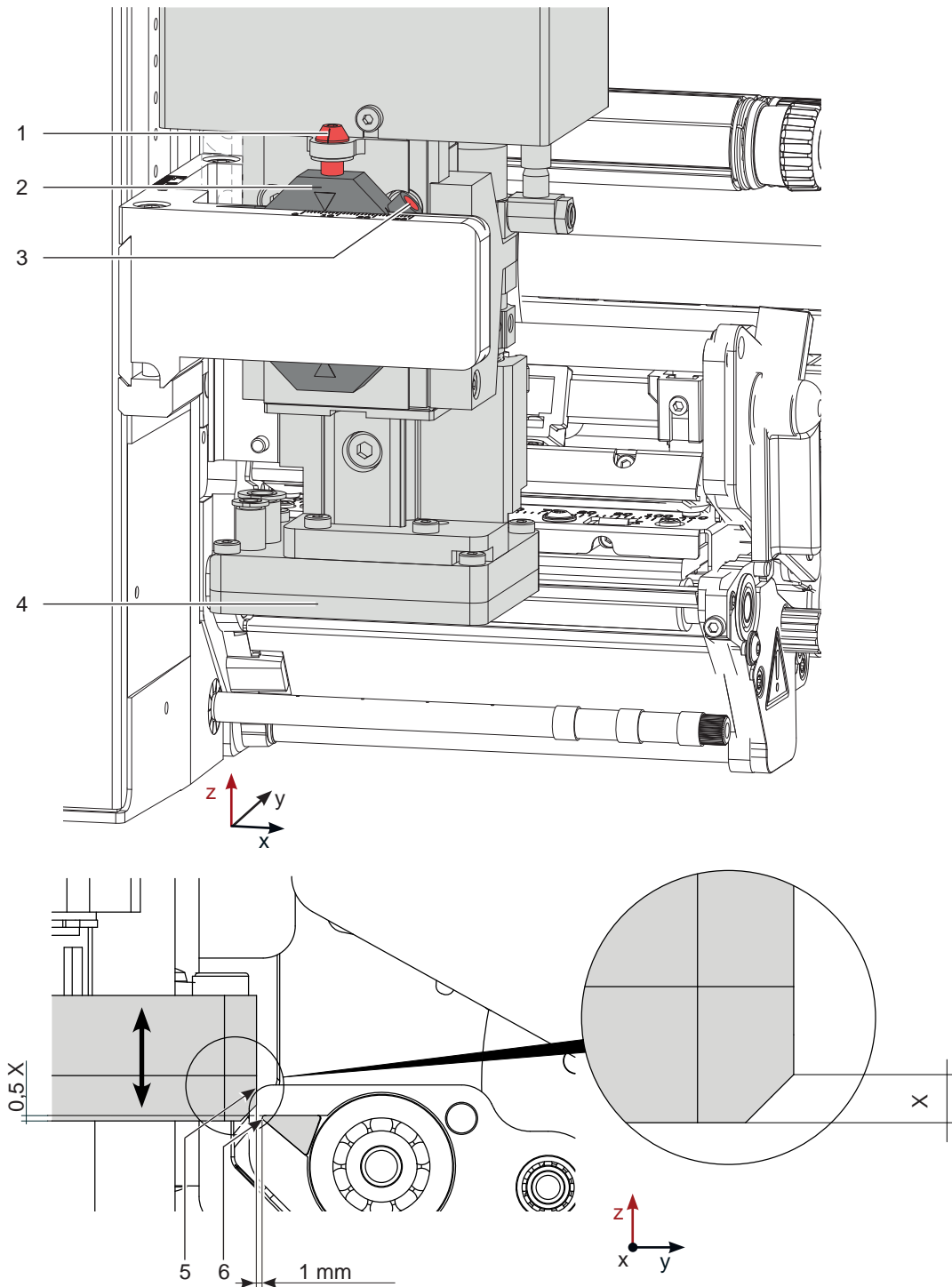

Fig. 11 Displacement in the Z direction

1. Loosen screw (3) on the binder (2).
2. Turn the setting screw (1) so that the bottom side of the pad (4) is 1 mm over the top of the dispensing plate (6) of the printer.
3. Tighten screw (3).

## 3.5.3 Moving the Pad in X-Direction

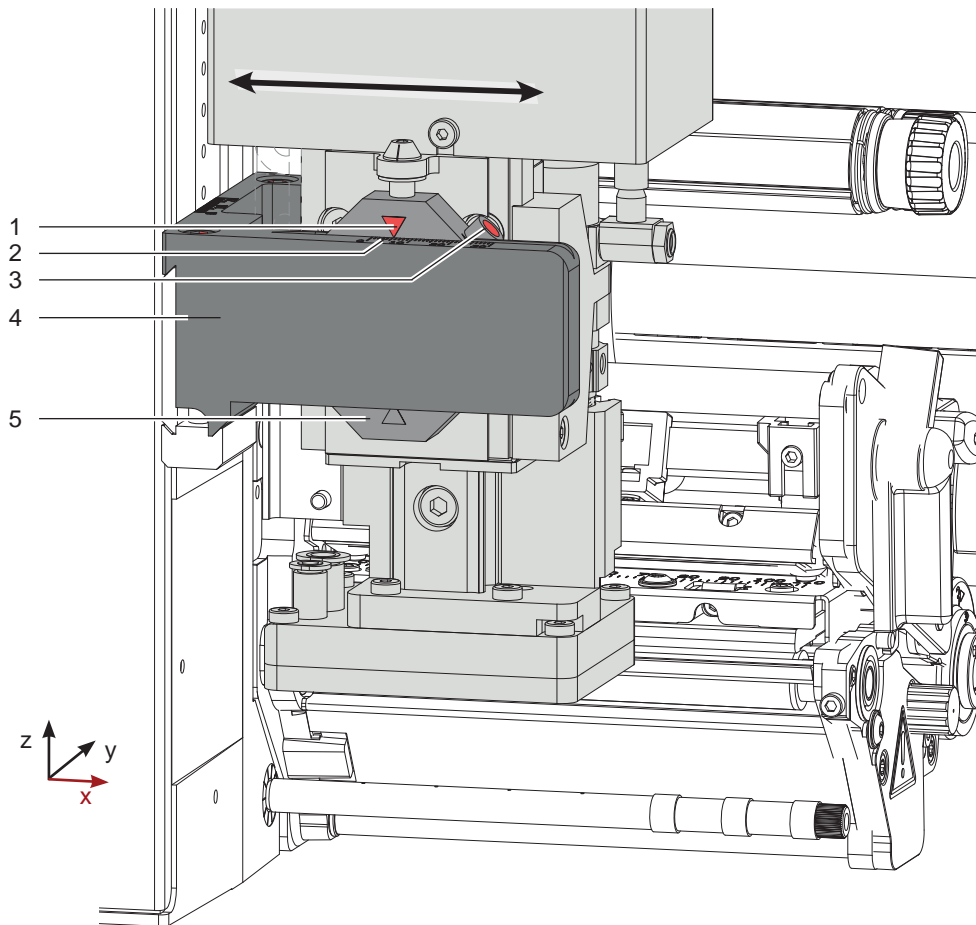

Fig. 12 Displacement in the Y direction

**Displacement in the X direction (Side)**

1. Loosen screw (3) on the binder (5).
2. Move cylinder assembly with the pad along the crossbeam (4) so that the dispensed label is aligned centrally to the pad. As reference use the provided graduation/ruler on the crossbeam.  
Orientation: Graduation (2) and Marking (1)
3. Tighten screw (3).

**Note!**

The settings in the printer configuration are basic settings for the specific printer-applicator combination. If the applicator or printer is changed, a new setting is required.

Adaptation to the respective print job must be carried out primarily via the software. Additional offset values are available here. The offset values from the device settings and the software add up during operation.

For detailed information about printer configuration ▷ [Printer configuration manual](#)

## 4.1 Settings in the Printer Menu











**Note!**

This guide only describes the specific contents of the *Labeling* menu.

More information about configuration ▷ [Printer configuration manual](#).

▶ Start menu.

▶ Select  *Setup* >  *Labeling*.

Parameter	Meaning	Default
 <i>Device info</i>	Provides device information, operational statistics and times in motion.	
 <i>Cycle sequence</i>	Setting the application mode <i>Print-Apply / Apply-Print</i> <i>Print-Apply:</i> An external start signal releases the print of a label and following the application of the label. After a cycle is complete, the pad without label waits in the home position. <i>Apply-Print:</i> An extra signal starts the print of the first label and the transfer of the label to the pad. The external start signal releases the application of the label and following the print and transfer of the next label. After a cycle is complete, the pad with a label is in the waiting position.	<i>Print-Apply</i>
 <i>Automatic FSTLBL</i>	* only with <i>Cycle sequence = Apply-print</i> The FSTLBL signal is triggered automatically in subsequence to a print job been started.	<i>Off</i>
 <i>Hand-over position</i>	Shift the position of the dispensed label relative to the dispensing edge. The setting can also be adjusted by the software. The settings of configuration and software are added together.	<i>0.0 mm</i>
 <i>Support delay on</i>	Setting the switch-on delay (max. 2,5 s) for the supporting air between print start and switching on the supporting air. The delay prevents swirling at the front of the label and, consequently, avoids faults when the label is being picked up from the printer.	<i>0 ms</i>
 <i>Support delay off</i>	Setting the switch-off delay (max. 2,5 s) for the supporting air between the end of label forwarding and switching on the supporting air. The delay can be useful to separate the rear edge of the label from the carrier to avoid errors and to improve the accuracy of label positioning	<i>270ms</i>
 <i>Start delay</i>	Delay (max. 2,5 s) between start signal and the start of an labelling cycle. Allows e.g. the use of product sensors at conveyors.	<i>0 ms</i>
 <i>Lock time</i>	All start signals coming in following the first start signal are ignored when they arrive within the lock time (max. 2,5 s).	<i>0 ms</i>
 <i>Blow time</i>	* Only at <i>Transfer mode = Blow on</i> Switch-on time (max. 2,5 s) of the blowing air for the label transfer	<i>100 ms</i>
 <i>Transfer mode</i>	Setting the operation mode <i>Stamp on, Roll on, Blow on</i>	<i>Stamp on</i>









Parameter	Meaning	Default
 <i>Waiting position</i>	* Only at <i>Transfer mode = Blow on</i> and <i>Cycle sequence = Apply-Print</i> <i>Home position:</i> Pad waits in the home position for the start signal <i>End position:</i> Pad waits in the labelling position for the start signal	<i>Home position</i>
 <i>Vacuum control</i>	Setting the label transfer check from printer to pad and from pad to product by the vacuum sensor	<i>On</i>
 <i>Cleaning blow</i>	Activation of a short blow impulse after the application of the label to clean the suction channels.	<i>On</i>
 <i>Vacuum delay</i>	<i>On</i> - The vacuum will be switched on after the label feed is completed. <i>Off</i> - The vacuum will be switched on when the label feed starts.	<i>Off</i>
 <i>START Mode</i>	Define the condition for triggering the START signal. Edge: from low to high Level: high	<i>Edge</i>
 <i>Pad empty delay</i>	Delay after the start of the backward movement of the cylinder movement before checking whether the label has been deposited.	<i>100 ms</i>
 <i>Print next label</i>	* only with <i>Cycle sequence = Apply-print</i> Initialization of the next print <i>Automatic:</i> The next label is printed automatically. <i>START Signal:</i> The START signal is required to print the next label. <i>FSTLBL Signal:</i> The FSTLBL signal is required to print the next label.	<i>Automatic</i>
 <i>Enable support air</i>	Activation / Deactivation of the support air	<i>On</i>

Table 2 Menu Labelling

## 4.2 Special JScript Commands

Some parameters of the menu *Setup > Labelling* can be changed or overridden by JScript commands in a print job.



### Attention!

- The meaning of the commands **O Ax=y** in the following table are valid for **HQ 4614** only. For other applicators the meaning of these commands are different.
- The y-values must be set as shown in the table regarding blanks and case sensitivity.
- Numerical entries must be entered in increments of ten.
- The changes are valid for the current print job only.

### Command O Ax=y

x	Meaning	Value range y	Default	Example
0	Support delay on in ms	0-2500	0	O A0=500
1	Support delay off in ms	0-2500	270	O A1=500
2	Start delay in ms	0-2500	0	O A2=500
3	Lock time in ms	0-5000	0	O A3=500
4	Blow time in ms	0-2500	1000	O A4=500
6	Transfer mode	Stamp on / Roll on / Blow on	Stamp on	O A6=Stamp on
8	Vacuum control	on / off	on	O A8=on
10	Cleaning blow	on / off	on	O A10=on
11	Vacuum delay	on / off	off	O A11=off
18	START Mode	Edge / Level	Edge	O A18=Edge
19	Pad empty delay in ms	0-1000	100	O A19=200

Table 3 O Ax commands

### 4.3 Setting the Hand-over Position

To optimize the transfer of the labels from the printer to the pad there are two different parameters available for adjusting the hand-over position.







#### Attention!

- ▶ First adjust the parameter "Hand-over position" in the printer configuration.
- ▶ Then adjust the additional hand-over position in the software.

It is very important to follow that procedure for a certain start after label loading and for the re-start after error treatment.

#### Parameter "Hand-over position" in the printer configuration

- ▶ Check the basic settings in the printer setup. Perform labelling cycles by alternately pressing the  button and Enter button  . ▷ „4.5 Test Mode without a Print Job“ on page 19
- ▶ In the submenu  *Labelling* >  *Hand-over position* adjust the "Hand-over position" in such a way, that the blank labels are peeled-off completely from the liner
  - ▷ „4.1 Settings in the Printer Menu“ on page 16

#### Hand-over position in the software

- ▶ Check the setting in the software. Perform labelling cycles by repeatedly pressing the Enter button  .
  - ▷ „4.6 Test Mode with a Print Job“ on page 19
- ▶ Adjust the hand-over position in such a way, that the printed labels are peeled-off completely from the liner
  - ▷ Programming manual or software documentation.

### 4.4 Activation of Peel-off Mode





#### Note!



- ▶ For labelling operation activate the peel-off mode in the software.
- ▶ For direct programming use the P command ▷ Programming manual.

## 4.5 Test Mode without a Print Job



Fig. 13 Display

By alternating between buttons  and  on the display it is possible to simulate the labeling process without an active printing job.

- ▶ Push button .
  - A blank label is dispensed and taken by the pad.
- ▶ Push button .
  - The pad is moved to the end position.
  - The label is transferred to the product.
  - The pad is moved back to the home position.



### Note!

- ▶ Use the printer configuration to find the best hand-over position for the initiation.

## 4.6 Test Mode with a Print Job

This method allows testing of the labeling process with actual printing data by using the  button.

- ▶ Send a print job.

The test mode is executed in two half cycles:

### Half cycle 1

- ▶ Push the  button.
  - A printed label is dispensed and taken over by the pad.

### Half cycle 2

- ▶ Push the  button again.
  - The pad is moved to the end position.
  - The label is transferred to the product.
  - The pad is moved back to the home position.



### Note!

- ▶ If the label is removed by hand after half cycle 1 has been completed and the  button is pressed, half cycle 1 will be repeated with the next label in the printing line.



### Note!

- ▶ Use the software to find the best hand-over position for the initiation.

## 5.1 Standard Operation

- ▶ Check all external connections.
- ▶ Load the material. Ensure that the locking system is locked ▷ "Operator's Manual" of the printer.
- ▶ Open the shutoff valve.



### Attention!

- ▶ Ensure that the pad is not covered by a label when switching on the printer-applicator system. Otherwise the vacuum sensor may be calibrated incorrectly.

- ▶ Switch on the printer.



### Note!

If the pad is outside the starting position when the printer-applicator system is switched on the procedure will be interrupted with an error message visible on the display.

Pushing the pause button on the printer will negate the error moving the pad to the starting position. The Applicator is ready for work.

- ▶ Press the  at the printer.  
A synchronization feed is initiated. The processed labels have to be removed manually. After a few seconds the printer carries out a short backfeed to position the front edge of the next label at the printing line.



### Note!

This synchronizing also has to be carried out when the print job has been interrupted with the  key. Synchronizing is not necessary when the print head was not lifted between print jobs. This also applies if the printer was powered off between print jobs.

- ▶ Start a print job.
- ▶ Start the labelling process via PLC interface.

Error messages during labelling process are shown in the display of the printer ▷ 4 Error Messages.

## 5.2 Cleaning



### Attention!

Never use solvent and abrasive.

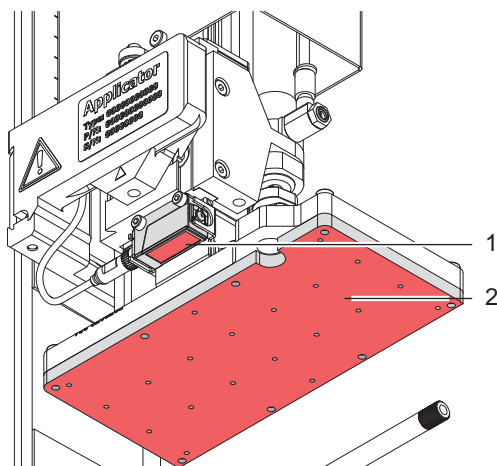

- ▶ Clean the outside surfaces with multi purpose cleaner.
- ▶ Remove dust particles and leftover label pieces with a soft brush and/or vacuum cleaner.
- ▶ The slide foil (1) requires regular cleaning as the most dirt is deposited here.
- ▶ Clean the surface of the product sensor with glass cleaner and a cotton bud.

Fig. 14 Cleaning pad with slide foil

## 6.1 Error Messages of the Printer

For detailed information about printer errors (e.g. *Paper out*, *Ribbon out*, etc.) ▷ Check the operator's manual of the printer.

Error treatment:

- ▶ Clearing the error results.
- ▶ Press the  to synchronize the label feed, remove the left over labels manually.

To quit the error state press *Repeat*.

After error correction, the label causing the error will be reprinted.

## 6.2 Error Messages of the Applicator

The following table contains an overview of error messages and their possible causes. It also suggests methods to resolve the problem :

Error message english	Cause	Error treatment
<i>Air Pressure to low: &lt;Value&gt; bar</i>	Pressure is too low < 4 bar	Increase pressure 4 to 6 bar
<i>Air Pressure to high: &lt;Value&gt; bar</i>	Pressure is too high > 6 bar	Reduce pressure 4 to 6 bar
<i>End position not reached within &lt;Value&gt; sec</i>	Pad does not reach the end position of the cylinder movement within the specified time	Increase cylinder speed (throttle valve) Check the sensor → adjust or replace sensor
<i>External stop</i>	Process was interrupted externally via I/O STOP.	Eliminate cause of external stop
<i>Home position left unauthorized</i>	Pad has left the starting position uncontrollably	Acknowledge error, applicator moves to the starting position.
<i>Home position not reached within &lt;value&gt; sec</i>	Pad does not reach the starting position of the cylinder movement within the specified time.	Increase cylinder speed (throttle valve) Check the sensor → adjust or replace sensor
<i>Intermediate position not reached within &lt;Value&gt; sec</i>	Pad does not reach the intermediate position of the cylinder movement within the specified time	Increase cylinder speed (throttle valve) Check the sensor → adjust or replace sensor
<i>Label lost during transport</i>	Label fell off the pad before it could be applied to the product.	Clean the pad Check vacuum
<i>Label not deposited</i>	Label was not applied to product and is still on the pad when the cylinder moves back.	Check the product position Check the lift length of the cylinder (Stopper)
<i>Label not taken</i>	Label was not transferred to the pad.	Check pad position Check vacuum
<i>Not in home position after power on</i>	Pad is outside the starting position.	Acknowledge error, applicator moves to the starting position.
<i>Sensor information not plausible</i>	Sensors are activated that should not be activated.	Check the sensor → adjust or replace sensor Check the applicator type in the setup

Table 4 Error messages of the applicator

**Error Treatment**

- ▶ Eliminate error consequences.

To continue operation, the following options are offered in the error display:

<i>Continue</i>	The current print job is continued with the next label.
<i>Cancel</i>	The current print job is cancelled.
<i>Repeat</i>	<ul style="list-style-type: none"> <li>* Only for error <i>Label not taken</i></li> </ul> The faulty label is printed again. <ul style="list-style-type: none"> <li>* For all other applicator errors, a new print job must be sent to reprint the faulty label.</li> </ul>

Table 5 Buttons in the error display

**Warning!**

**After the error has been resolved the pad will immediately move back to the home position!**

**Danger of injury to hands and fingers by the moving pad!**

- ▶ **Do not reach into the area of the moving pad and keep long hair, loose clothes, and jewelry away.**

- ▶ With *Cycle sequence=Apply-Print*, before starting cyclical operation, send the FSTLBL signal or press  to transfer a printed label to the pad.

## 7.1 Declaration of Incorporation



cab Produkttechnik  
GmbH & Co KG  
Wilhelm-Schickard-Str. 14  
D-76131 Karlsruhe  
Germany

### EC Declaration of Incorporation

We declare herewith that the following „partly completed machinery“ as a result of design, construction and the version put in circulation complies with the essential requirements of the Directive 2006/42/EC on machinery :

Annex I, Article 1.1.2, 1.1.3, 1.1.5, 1.1.6, 1.2.1, 1.3.2, 1.5.2, 1.5.8, 1.6.3, 1.7

In the event of any alteration which has not been approved by us being made to any device as designated below, this statement shall thereby be made invalid.

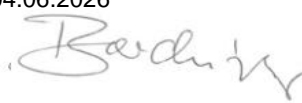
Device	<b>Stroke-Blow Applicator</b>
Type	<b>HQ 4614</b>
Applied EU Regulations	Applied Standards
<b>Directive 2006/42/EC on machinery</b>	<b>EN ISO 12100:2010</b>
	<b>EN ISO 13849-1:2015</b>
	<b>EN 62368-1: 2014/AC:2015</b>
Other Relevant Directives	
<ul style="list-style-type: none"> <li>• <b>Directive 2014/30/EU relating to electromagnetic compatibility</b></li> <li>• <b>Directive 2011/65/EU on the restriction of the use of certain hazardous substances in electrical and electronic equipment</b></li> </ul>	
Person authorised to compile the technical file	<b>Marcel Michalski</b> <b>Am Unterwege 18/20</b> <b>99610 Sömmerda</b>
Signed for, and on behalf of the Manufacturer	Karlsruhe, 04.06.2026
<b>cab Produkttechnik GmbH &amp; Co KG</b> <b>Wilhelm-Schickard-Str. 14</b> <b>D-76131 Karlsruhe</b>	 <b>Klaus Bardutzky</b> Managing Director

The product must not be put into service until the final machinery into which it is to be incorporated has been declared in conformity with the provisions of the Directive on machinery.

The documents according annex VII part B from the incomplete machinery are created and will commit to state agencies on request in electronic kinds.

## 7.2 EU Declaration of Conformity



cab Produkttechnik  
GmbH & Co KG  
Wilhelm-Schickard-Str. 14  
D-76131 Karlsruhe  
Germany

### EU Declaration of Conformity

We declare herewith that the following device as a result of design, construction and the version put in circulation complies with the relevant fundamental regulations of the EU Rules for Safety and Health. In the event of any alteration which has not been approved by us being made to any device as designated below, this statement shall thereby be made invalid.

Device	<b>Stroke-Blow Applicator</b>
Type	<b>HQ 4614</b>
Applied EU Regulations	Applied Standards
<b>Directive 2014/30/EU relating to electromagnetic compatibility</b>	<b>EN 55032:2015+A11:2020</b>
	<b>EN 55035:2017+A11:2020</b>
	<b>EN 61000-6-2:2005/AC:2005</b>
<b>Directive 2011/65/EU on the restriction of the use of certain hazardous substances in electrical and electronic equipment</b>	<b>EN IEC 63000:2018</b>
<b>Commission delegated directive (EU) 2015/863 amending Annex II to Directive 2011/65/EU of the European Parliament and of the Council as regards the list of restricted substances</b>	
Signed for, and on behalf of the Manufacturer	Karlsruhe, 04.06.2026
<b>cab Produkttechnik GmbH &amp; Co KG</b> <b>Wilhelm-Schickard-Str. 14</b> <b>D-76131 Karlsruhe</b>	 <b>Klaus Bardutzky</b> Managing Director