

Assembly Instructions



Stroke Applicator

HQ 4024

Family	Type
Stroke Applicator	HQ 4024L-200
	HQ 4024L-300
	HQ 4024L-400
	HQ 4024L-600
	HQ 4024R-200
	HQ 4024R-300
	HQ 4024R-400
	HQ 4024R-600

Edition: 03/2026 - Part No. 9004205

Copyright

This documentation as well as translation hereof are property of cab Produkttechnik GmbH & Co. KG.

The replication, conversion, duplication or divulgement of the whole manual or parts of it for other intentions than its original intended purpose demand the previous written authorization by cab.

Editor

Regarding questions or comments please contact cab Produkttechnik GmbH & Co. KG.

Topicality

Due to the constant further development of our products discrepancies between documentation and product can occur. Please check www.cab.de for the latest update.

Terms and conditions

Deliveries and performances are effected under the General conditions of sale of cab.

Germany
cab Produkttechnik GmbH & Co KG
Karlsruhe
Phone +49 721 6626 0
www.cab.de

USA
cab Technology, Inc.
Chelmsford, MA
Phone +1 978 250 8321
www.cab.de/us

Taiwan
cab Technology Co., Ltd.
Taipei
Phone +886 (02) 8227 3966
www.cab.de/tw

Singapore
cab Singapore Pte. Ltd.
Singapore
Phone +65 6931 9099
www.cab.de/en

France
cab Technologies S.à.r.l.
Niedermodern
Phone +33 388 722501
www.cab.de/fr

Mexico
cab Technology, Inc.
Juárez
Phone +52 656 682 4301
www.cab.de/es

China
cab (Shanghai) Trading Co., Ltd.
Shanghai
Phone +86 (021) 6236 3161
www.cab.de/cn

South Africa
cab Technology (Pty) Ltd.
Randburg
Phone +27 11 886 3580
www.cab.de/za

1	Introduction	4
1.1	Instructions.....	4
1.2	Intended Use.....	4
1.3	Safety Instructions.....	4
1.4	Safety Markings	5
1.5	Environment.....	5
2	Product Description.....	6
2.1	Important Features.....	6
2.2	Technical Data.....	6
2.3	Overview	7
2.4	Contents of Delivery.....	8
2.5	Pads.....	9
2.5.1	Universal Pads	9
2.5.2	Roll-on pad 4014L/R-4100/4016L/R-4100	9
2.5.3	Blow pad 4014L/R-21xx	9
2.5.4	Corner pad 4014L/R-5100.....	9
3	Mounting.....	10
3.1	Mounting the Blow Tube.....	11
3.2	Piercing the Universal Pad Sliding Foil	11
3.3	Preparing the Applicator for the Spring Mounted Pad 401x-4x00.....	12
3.4	Mounting the Pad.....	12
3.5	Adjusting the Pad.....	13
3.5.1	Moving the Pad in Y-Direction	14
3.5.2	Moving the Pad in Z-Direction	15
3.5.3	Moving the Pad in X-Direction.....	16
4	Operation	17
4.1	Standard Operation.....	17
4.2	Cleaning.....	17
5	Configuration.....	18
5.1	Setting in the printer menu	18
5.2	Special JScript Commands	19
6	Error Messages	20
6.1	Error Messages of the Printer	20
6.2	Error messages of the applicator	20
7	Licences.....	22
7.1	Declaration of Incorporation	22
7.2	EU Declaration of Conformity.....	23

1.1 Instructions

Important information and instructions in this documentation are designated as follows:



Danger!

Draws attention to an exceptionally great, imminent danger to your health or life due to hazardous voltages.



Danger!

Draws attention to a danger with high risk which, if not avoided, may result in death or serious injury.



Warning!

Draws attention to a danger with medium risk which, if not avoided, may result in death or serious injury.



Caution!

Draws attention to a danger with low risk which, if not avoided, may result in minor or moderate injury.



Attention!

Draws attention to potential risks of property damage or loss of quality.



Note!

Advice to make work routine easier or on important steps to be carried out.



Environment!

Gives you tips on protecting the environment.



Handling instruction.



Reference to section, position, illustration number or document.



Option (accessories, peripheral equipment, special fittings).

Time

Information in the display.

1.2 Intended Use

- The device is manufactured in accordance with the current technological status and the recognized safety rules. However, danger to life and limb of the user or third parties and/or damage to the device and other tangible assets can arise during use.
- The device may only be used for its intended purpose and if it is in perfect working order, and it must be used with regard to safety and dangers as stated in the manual.
- The device is designed to use on a cab printer of the HERMES QL and HERMES Q series. Any other use or use going beyond this shall be regarded as improper use. The manufacturer/supplier shall not be liable for damage resulting from unauthorized use; the user shall bear the risk alone.
- Usage for the intended purpose also includes complying with the manual, including the manufacturer's maintenance recommendations and specifications.



Note!

The complete and current version of the documentation can be found in the Internet.

1.3 Safety Instructions



Attention!

Initiation, adjustments and changing of parts are to be performed by qualified service personnel only.



Warning!

This is a class A product. In a domestic environment this product may cause radio interference in which case the user may be required to take adequate measures.

- Before mounting the delivered components disconnect the printer from the power supply and close the shutoff valve of the applicator.
- Only connect the device to other devices which have a protective low voltage.
- Switch off all affected devices (computer, printer, accessories) before connecting or disconnecting.
- In operation, moving parts are easily accessible.
This applies especially for the zone, where the pad is moved between the starting and the labelling position. During operation do not reach into that zone and keep long hair, loose clothes, and jewelry distant. Before any manipulations in those areas, close the shutoff valve.
- The device may only be used in a dry environment, do not expose it to moisture (sprays of water, mists, etc.).
- Do not use the device in an explosive atmosphere.
- Do not use the device close to high-voltage power lines.
- Perform only those actions described in this manual.
Work going beyond this may only be performed by trained personnel or service technicians.
- Unauthorized interference with electronic modules or their software can cause malfunctions.
- Other unauthorized work on or modifications to the device can also endanger operational safety.
- Always have service work done in a qualified workshop, where the personnel have the technical knowledge and tools required to do the necessary work.
- There are various warning stickers on the device. They draw your attention to dangers. Warning stickers must therefore not be removed, as then you and other people cannot be aware of dangers and may be injured.

1.4 Safety Markings

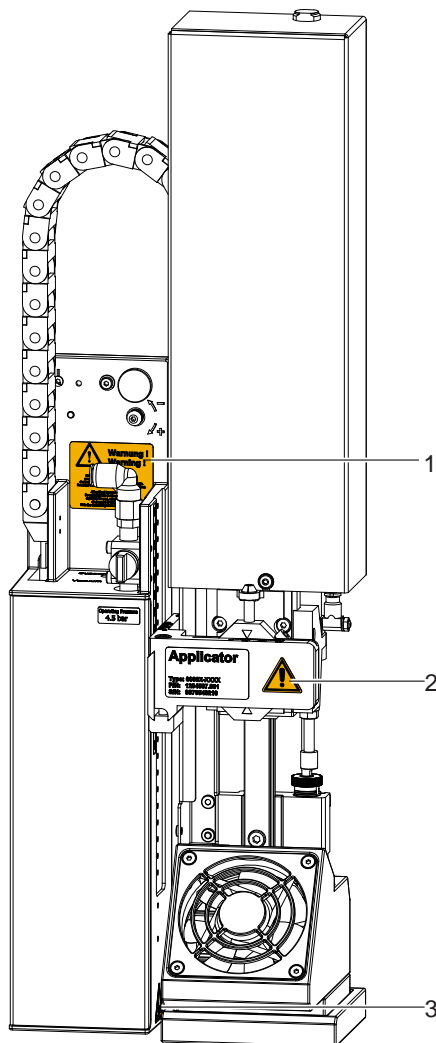

- 1: Risk of injuries by moving parts!
- 2: The cylinder is under pressure also if the printer is switched off. Possibility of residual energy!
- 3: Danger of crushing hands and fingers by the moving pad!

Attention!
Never remove or cover safety markings!
Replace it in case of damage!

Fig. 1 Safety marking

1.5 Environment



Obsolete devices contain valuable recyclable materials that should be sent for recycling.

- ▶ Send to suitable collection points, separately from residual waste.
The modular construction of the print module enables it to be easily disassembled into its component parts.
- ▶ Send the parts for recycling.

2.1 Important Features

- The speed of the cylinder and the fan power are adjustable. Thus the applicator can be adjusted to different label materials and sizes.
- To avoid contamination within the vacuum channels they are cleaned by an air pressure pulse at the end of each application.
- For operation in a system the I/O interface of the printer can be used.

2.2 Technical Data

Stroke applicators		HQ 4024 L/R-200	HQ 4024 L/R-300	HQ 4024 L/R-400	HQ 4024 L/R-600
Distance of a package to the bottom of the unit	up to mm	135	235	335	535
Package heights	variable	■			
Alternation in the heights of packages	mm max.	100	200	300	500
Label applications		from the top, from below, from the side			from the top
State of a package at the moment a label is applied	at rest	■			
Controls	Sensor 1	initial / upper end position			
	Sensor 2	label on vacuum pad			
	Sensor 3	label application / lower end position			
Consumption of power	W max.	30			
Compressed air	bar	4.5			
Cycle rate ¹⁾	labels/min approx.	30			

¹⁾ calculated using a stroke of 100 mm below the unit, labels 40 mm high, a print speed of 100 mm/s

Vacuum pad

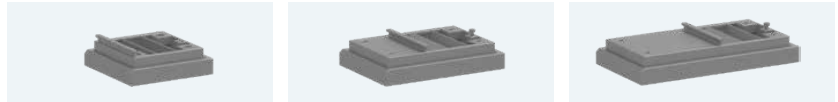

Vacuum pad			4024-3000 105 x 100	4024-3000 105 x 150	4024-3000 105 x 200
Label	Width	mm	50 - 105	50 - 105	50 - 105
	Height	mm	40 - 100	80 - 150	120 - 200
	Thickness	µm	110	110	110

Table 1 Technical Data

2.3 Overview

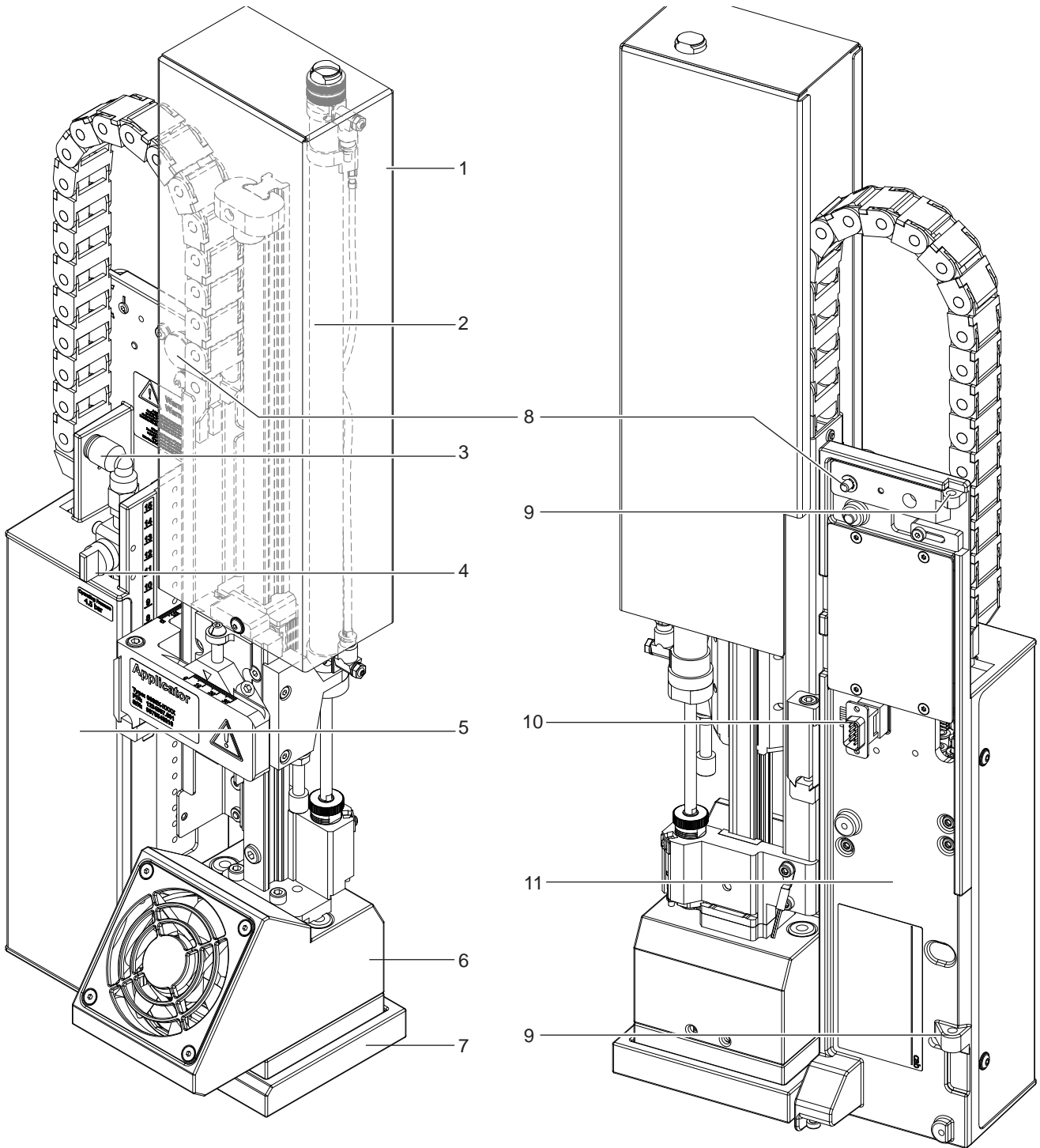
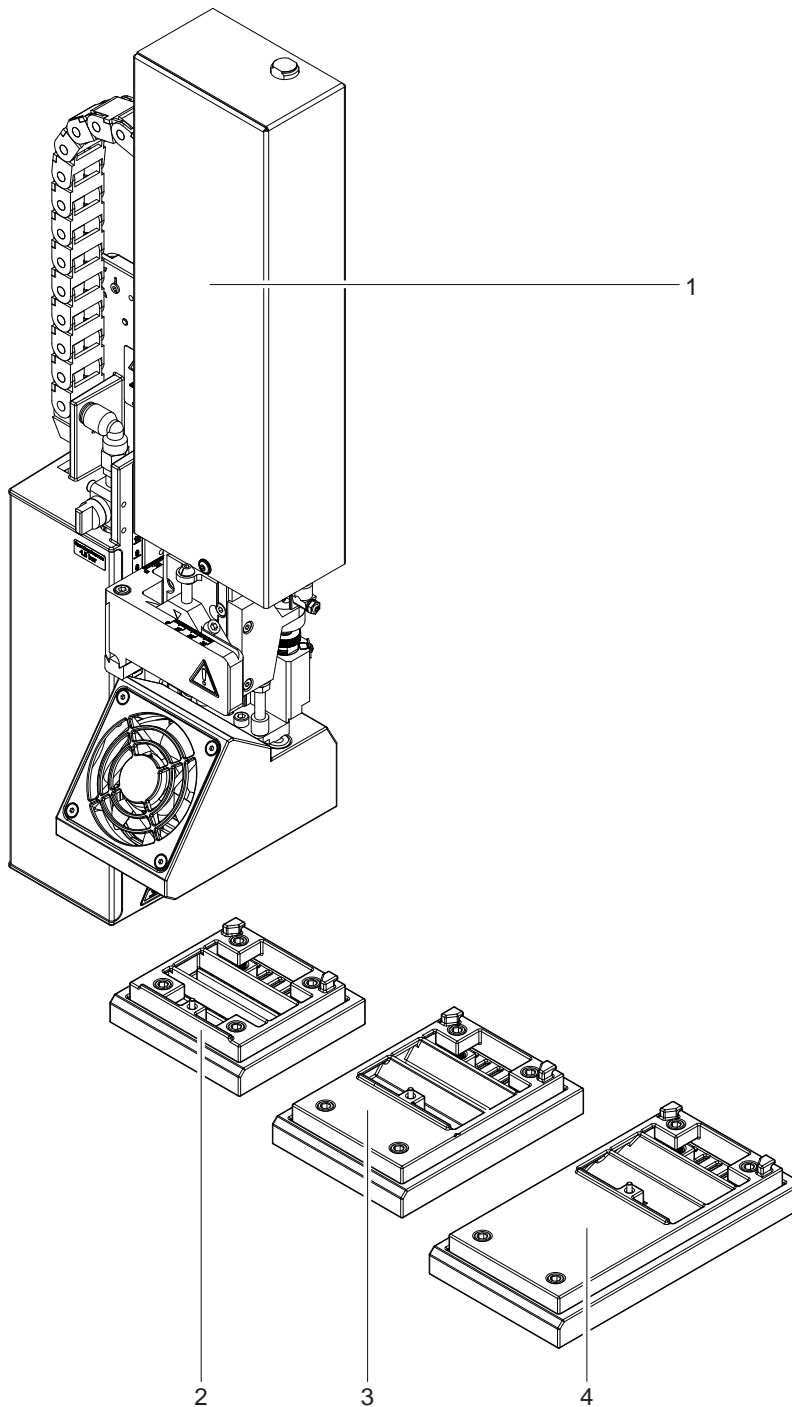

Fig. 2 Device overview - front view

- 1 Cover
- 2 Lift cylinder
- 3 Compressed air connector
- 4 Shutoff valve
- 5 Control unit
- 6 Fan assembly
- 7 Vacuum pad (customized)

- 8 Knurled screw for attaching the applicator to the printer
- 9 Hinges
- 10 SUB-D 15 interface to the printer
- 11 Mounting plate

2.4 Contents of Delivery



1. Applicator
2. Vacuum pad 5989301
4024-3000 105 x 100 HQ oder
3. Vacuum pad 5989302
4024-3000 105 x 150 HQ oder
4. Vacuum pad 5989303
4024-3000 105 x 200 HQ
5. Documentation

Fig. 3 Contents of delivery

**Note!**

Please keep the original packaging in case the applicator must be returned.

**Attention!**

The device and printing materials will be damaged by moisture and wetness.

► Set up label printer with applicator only in dry locations protected from splash water.

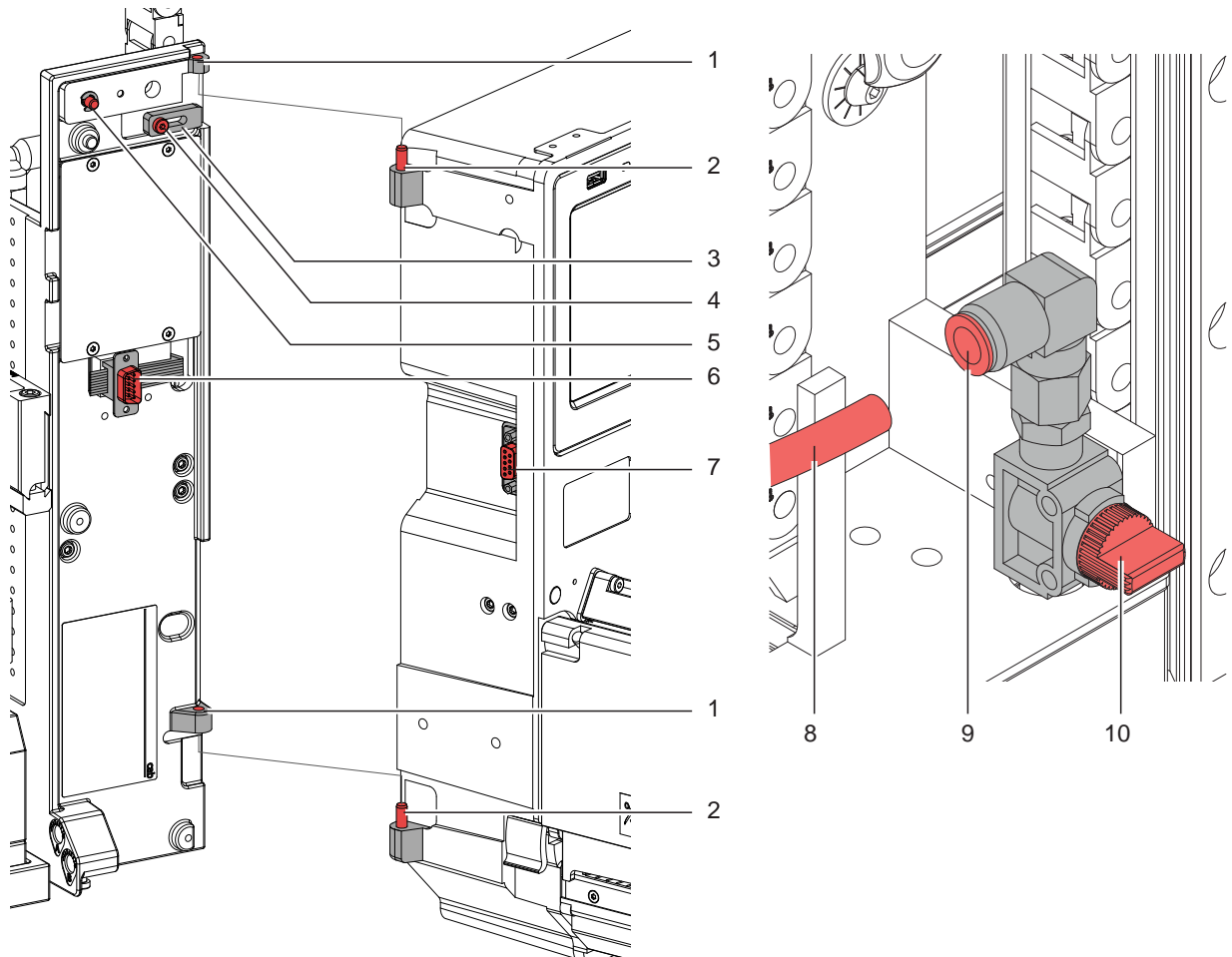

Fig. 4 Mounting applicator on printer



Attention!

Initiation, adjustments and changing of parts is only for qualified service personal only.

▷ Service Manual

Mount the applicator

1. Hang the applicator with the female part of hinges (1) at the printer mounted hinges parts (2).
2. Connect SUB-D 15 male connector (6) to the female connector (7) of the printer.
3. To prevent the applicator from slipping out of the hinges loosen screw (4) and move the locking plate (3) under the hinges and tighten screw (4).
4. Swing the applicator to the printer and tighten the thumbscrew (5).
5. Keep the external compressed air supply closed and close the shut-off valve (10) on the applicator ▷ see illustration
6. Insert external compressed air supply (8) into the plug connector (9) on the shut-off valve (10).
7. Switch on compressed air and open shut-off valve (10) by turning 90 °.

For cleaning the applicator and printer it's sometime necessary to turn away or/and dismantle the applicator. Don't change the adjustments of setting screws, throttle valves or other.

Turn away/Dismount the applicator

8. To turn away the applicator loosen thumbscrew (5) and swing the applicator aside.
9. Disconnect SUB-D 15 male connector (6) to the female connector (7) of the printer.
10. Loosen screw (4) and move off the locking plate (3) from the hinges.
11. Lift the applicator upward.

3.1 Adjusting the Pad

For the perfect application of labels it is necessary that the pad is placed precisely above the dispensed label.

Aligning the pad parallel to the blade / dispensing plate

The edge of the pad should be positioned parallel to the blade / dispensing plate of the printer in order to position the label exactly on the pad.

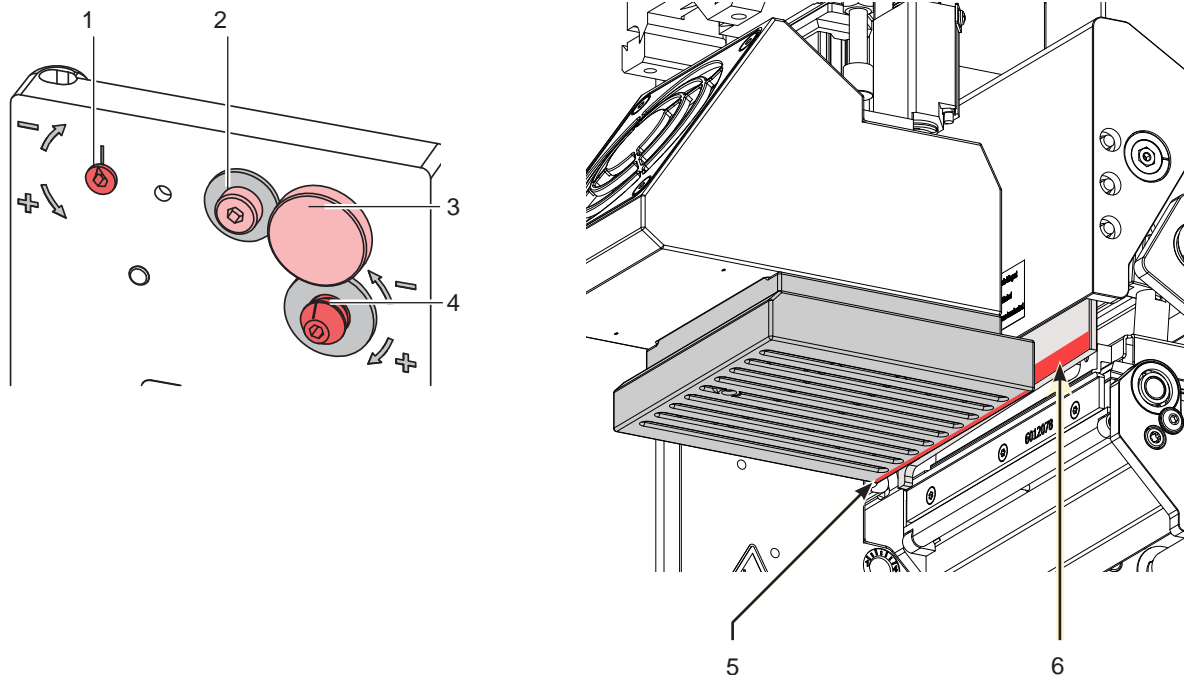
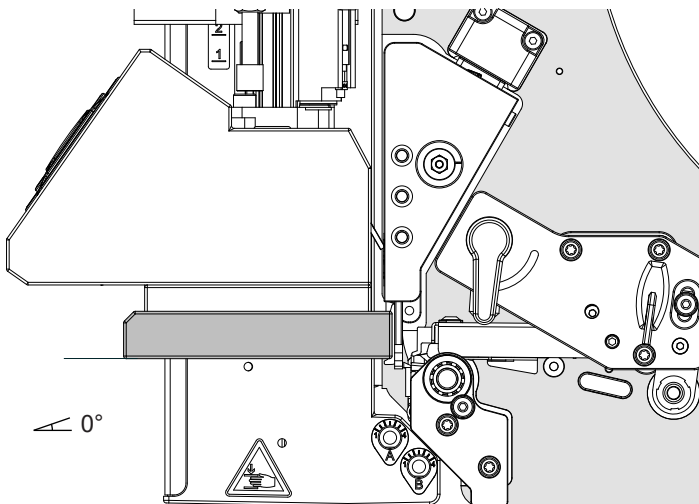

Fig. 5 Aligning the pad to the dispensing plate

1. Loosen the knurled screw (3) and the set screw (4).
2. Screw in the knurled screw (3) until the pad edges (5) are aligned parallel to the blade (6) of the HERMES QL printer or the dispensing edge (6) of the HERMES Q printer.
3. Tighten the set screw (4) until it touches the printer.

Aligning the pad at an angle to the dispensing plate



4. If the angle between the pad surface and the bottom edge of the printer is not 0 ° loosen screw (2).
5. Correct the angle of attack by turning the eccentric (1).
6. Tighten screw (2).

3.1.1 Moving the Pad in Y-Direction

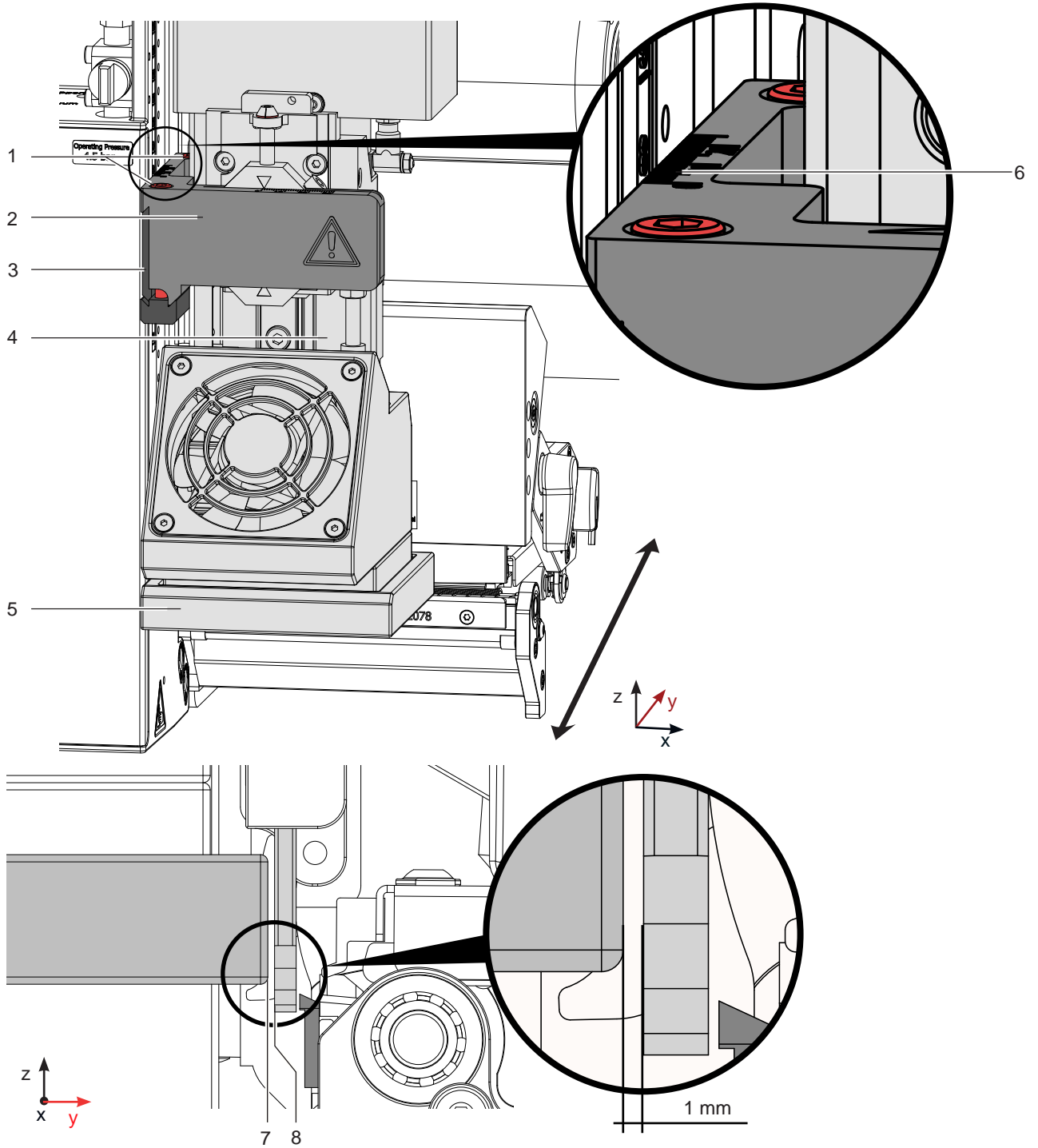

Fig. 6 Displacement in the Y direction

Displacement in the Y direction (printing direction)

1. Loosen screws (1) on the cross beam (2).
2. Move cylinder assembly (4) with the pad (5) and crossbeam (2) along the guiding rail (3) that the distance from the edge of the pad (7) to the blade of the HERMES QL printer or edge the dispensing plate (8) of the HERMES Q printer is approximately 1 mm.
Orientation: Graduation (6)
3. Tighten screws (1).

3.1.2 Moving the Pad in Z-Direction

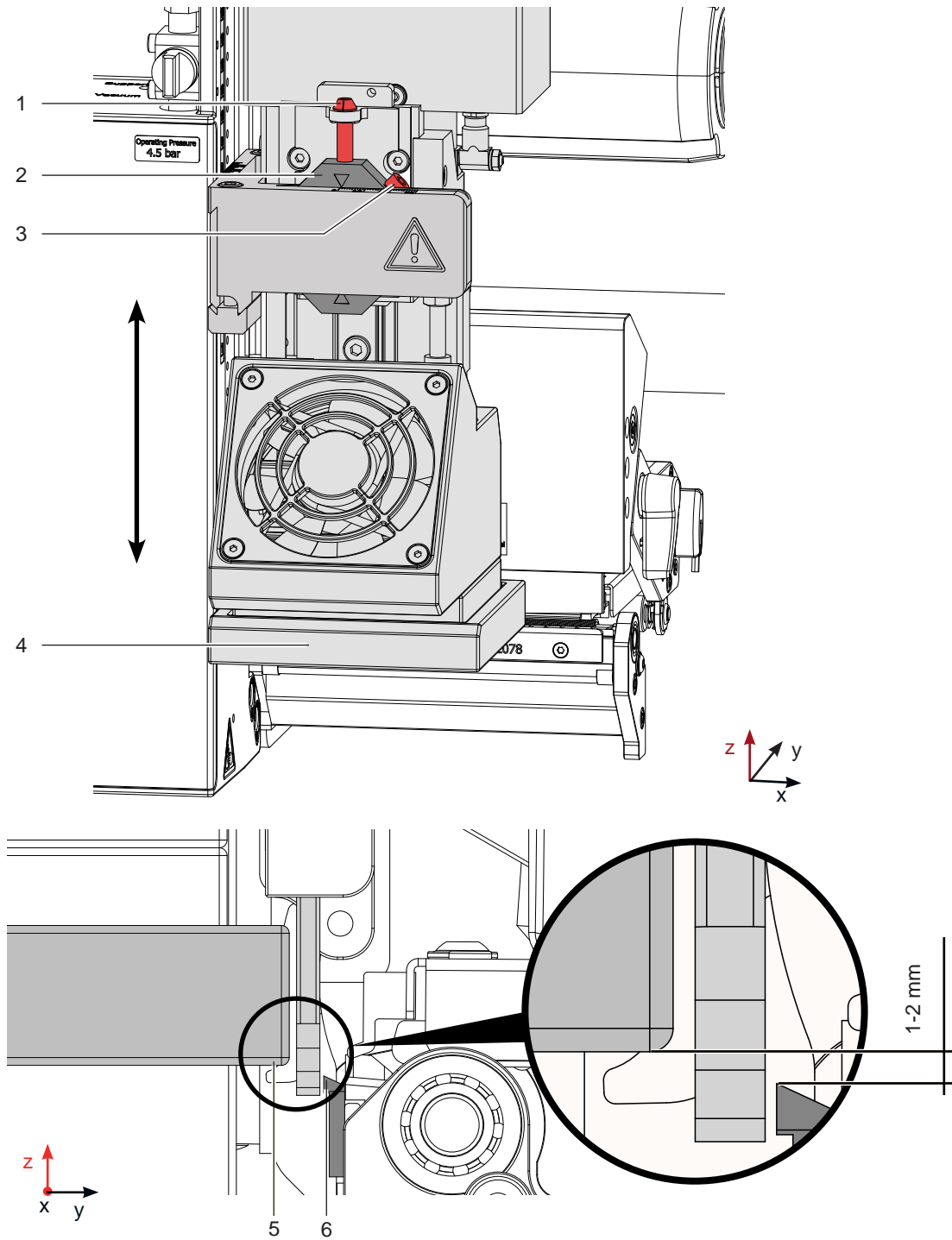

Fig. 7 Displacement in the Z direction

1. Loosen screw (3) on the binder (2).
2. Turn the setting screw (1) so that the bottom side of the pad (4) is 1 mm over the top edge of the blade beam (6) from the HERMES QL printer or top of the dispensing plate (6) from the HERMES Q printer. of the printer.
3. Tighten screw (3).

3.1.3 Moving the Pad in X-Direction

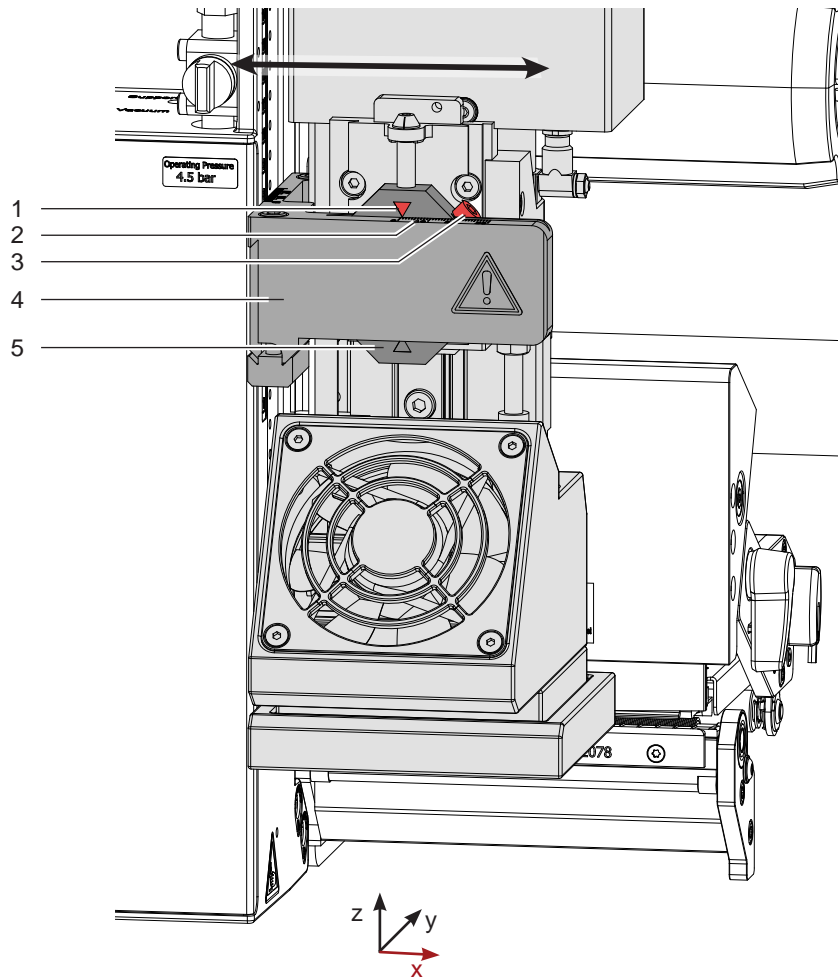

Fig. 8 Displacement in the Y direction

Displacement in the X direction (Side)

1. Loosen screw (3) on the binder (5).
2. Move cylinder assembly with the pad along the crossbeam (4) so that the dispensed label is aligned centrally to the pad. As reference use the provided graduation/ruler on the crossbeam.
Orientation: Graduation (2) and Marking (1)
3. Tighten screw (3).

4.1 Standard Operation

- ▶ Check all external connections.
- ▶ Load the material. Ensure that the locking system is locked ▷ "Operator's Manual" of the printer.
- ▶ Open the shutoff valve.



Attention!

- ▶ Ensure that the pad is not covered by a label when switching on the printer-applicator system. Otherwise the vacuum sensor may be calibrated faultily.

- ▶ Switch on the printer.



Note!

In case the pad is outside the start position in the moment of switching on it will interrupted the procedure and give notice an error message on the display of the printer.

If you push the button pause on the printer is receipt the error and the applicator will move into the start position.

The Applicator is ready for work.

- ▶ Press the  at the printer.
A synchronization feed is released. The processed labels have to be removed manually. After a few seconds the printer carries out a short backfeed to position the front edge of the next label at the printing line.



Note!

This synchronizing also has to be carried out when the print job has been interrupted with the cancel key. Synchronizing is not necessary when the print head was not lifted between print jobs. This also applies if the printer was powered off between print jobs.

- ▶ Start a print job
- ▶ Start the labelling process via PLC interface.

Error messages during labelling process are shown in the display of the printer ▷ Error Messages.

4.2 Cleaning



Attention!

Never use solvent and abrasive.

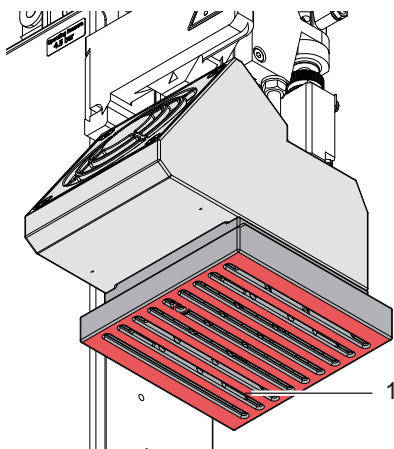

- ▶ Clean the outside surfaces with multi purpose cleaner.
- ▶ In regularly function it's possible that accrue dust particles and label splits. Remove that by a soft brush or/and a vacuum cleaner.
- ▶ Especially at slide foil (1) it's possible that fouling deposit. To receive an ideal takeover and handling of the label it's necessary to clean the surface of slide foil at regular intervals.

Fig. 9 Cleaning pad with slide foil

**Note!**

The settings in the printer configuration are basic settings for the specific printer-applicator combination. If the applicator or printer is changed, a new setting is required.

Adaptation to the respective print job must be carried out primarily via the software. Additional offset values are available here. The offset values from the device settings and the software add up during operation.

For detailed information about printer configuration ▷ [Printer configuration manual](#)

5.1 Setting in the printer menu











**Note!**

This guide only describes the specific contents of the *Labeling* menu.

More information about configuration ▷ [Printer configuration manual](#).

▶ Start menu.

▶ Select  *Setup* >  *Labeling*.

Parameter	Meaning	Default
 <i>Device informationen</i>	Informationen about applicator type, firmware version as well as statistics on applied labels, faulty labels and application processes, number of application cycles, application times and fan speed.	
 <i>Cycle sequence</i>	Setting the application mode <i>Print-Apply / Apply-Print</i> <i>Print-Apply:</i> An external start signal releases the print of a label and following the application of the label. After a cycle is complete, the pad without label waits in the start position. <i>Apply-Print:</i> An extra signal FSTLBL starts the print of the first label and the transfer of the label to the pad. The external start signal releases the application of the label and following the print and transfer of the next label. After a cycle is complete, the pad with a label is in the waiting position.	<i>Print-Apply</i>
 <i>Automatic FSTLBL</i>	* only with <i>Cycle sequence = Apply-print</i> The FSTLBL signal is triggered automatically in subsequence to a print job been started.	<i>Off</i>
 <i>Start delay</i>	Delay (max. 2,5 s) between start signal and the start of an labelling cycle. Allows e.g. the use of product sensors at conveyors.	<i>0 ms</i>
 <i>Lock time</i>	All start signals coming in following the first start signal are ignored when they arrive within the lock time (max. 2,5 s).	<i>0 ms</i>
 <i>Transfer mode</i>	Setting the operation mode <i>Stamp on, Roll on, Blow on</i>	<i>Stamp on</i>
 <i>Vacuum control</i>	Setting the label transfer check from printer to pad and from pad to product by the vacuum sensor	<i>On</i>
 <i>Cleaning blow</i>	Activation of a short blow impulse after the application of the label to clean the suction channels.	<i>On</i>
 <i>Vacuum delay</i>	<i>On</i> - The vacuum will be switched on after the label feed is completed. <i>Off</i> - The vacuum will be switched on when the label feed starts.	<i>Off</i>
 <i>START Mode</i>	Define the condition for triggering the START signal. Edge: from low to high Level: high	<i>Level</i>



Parameter	Meaning	Default
 <i>Pad empty delay</i>	Delay after the start of the backward movement of the cylinder movement before checking whether the label has been deposited.	100 ms
 <i>Fan power</i>	Power of the fan 15% to 100%	100%

Table 2 Menu Labelling

5.2 Special JScript Commands



Note!

Some parameters of the menu *Setup > Labelling* can be changed or overridden by JScript commands in a print job. Numerical entries must be entered in increments of ten. These changes are valid for the current print job only.



Attention!

The meaning of the commands **O Ax=y** in the following table are valid for SQ 3200 only. For other applicators the meaning of these commands are different.

Command **O Ax=y**

x	Meaning	Value range y	Default	Example
0	Support delay on in ms	0-2500	0	O A0=500
1	Support delay off in ms	0-2500	270	O A1=500
2	Start delay in ms	0-2500	0	O A2=500
3	Lock time in ms	0-5000	0	O A3=500
4	Blow time in ms	0-2500	1000	O A4=500
6	Transfer mode	Stamp on / Roll on / Blow on	Stamp on	O A6=Stamp on
8	Vacuum control	on / off	on	O A8=on
10	Cleaning blow	on / off	on	O A10=on
18	START Mode	Edge / Level	Edge	O A18=Edge
19	Pad empty delay in ms	0-1000	100	O A19=200

Table 3 O Ax commands



Attention!

The y-values must be set as shown in the table regarding blanks and case sensitivity.

6.1 Error Messages of the Printer

For detailed information about printer errors (e.g. 'Paper out', 'Ribbon out', etc.) ▷ Check the operator's manual of the printer.

Error treatment:

▶ Clearing the error results.

▶ Press the  to synchronize the label feed, remove the left over labels manually.

To quit the error state press *Repeat* .

After error correction, the label causing the error will be reprinted.

6.2 Error messages of the applicator

The following table contains an overview of error messages and their possible causes. It also suggests methods to resolve the problem :

Error message english	Cause	Error treatment
<i>Air Pressure to low: <Value> bar</i>	Pressure is too low < 4 bar	Increase pressure 4 to 6 bar
<i>Air Pressure to high: <Value> bar</i>	Pressure is too high > 6 bar	Reduce pressure 4 to 6 bar
<i>Label not deposited</i>	Label was not applied to product and is still on the stamp when the cylinder moves back.	Check the product position Check the lift length of the cylinder (Stopper)
<i>Not in home position after power on</i>	Stamp is outside the starting position.	Acknowledge error, applicator moves to the starting position.
<i>Home position not reached within <value> sec</i>	Stamp does not reach the starting position of the cylinder movement within the specified time.	Increase cylinder speed (throttle valve) Check the sensor → adjust or replace sensor
<i>Home position left unauthorized</i>	Stamp has left the starting position uncontrollably	Acknowledge error, applicator moves to the starting position.
<i>External stop</i>	Process was interrupted externally via I/O STOP.	Eliminate cause of external stop
<i>Label not taken</i>	Label was not transferred by the stamp.	Check stamp position Check vacuum
<i>Label lost during transport</i>	Label fell off the stamp before it could be applied to the product.	Stempel reinigen Vakuum überprüfen
<i>End position not reached within <Value> sec</i>	Stamp does not reach the end position of the cylinder movement within the specified time	Increase cylinder speed (throttle valve) Check the sensor → adjust or replace sensor
<i>Sensor information inot plausible</i>	Sensors are activated that should not be activated.	Check the sensor → adjust or replace sensor Check the applicator type in the setup

Table 4 Error messages of the applicator

Error treatment:

- ▶ Clear the error state.
- ▶ In order to clear the error state press **continue**, **repeat** or **cancel**.
 - Continue* with the next label in the printing queue.
 - Repeat* repeat the print of the label causing the error.
Only applicable with error *Vac. plate empty*.
 - Cancel* the current print job.



Warning!

After the error has been resolved the pad will immediately move back to the starting position!

Danger of injury to hands and fingers by the moving pad!

- ▶ **Do not reach into the area of the moving pad and keep long hair, loose clothes, and jewelry away.**

Reprinting a label, interrupted by an error, is not possible without a new printing job.

- ▶ In the mode "apply/print" before the standard cyclic operation can commence the signal "print first label" must be sent or push  to send a printed label to the pad.

7.1 Declaration of Incorporation



cab Produkttechnik
GmbH & Co KG
Wilhelm-Schickard-Str. 14
D-76131 Karlsruhe
Germany

EC Declaration of Incorporation

We declare herewith that the following „partly completed machinery“ as a result of design, construction and the version put in circulation complies with the essential requirements of the Directive 2006/42/EC on machinery :

Annex I, Article 1.1.2, 1.1.3, 1.1.5, 1.1.6, 1.2.1, 1.3.2, 1.5.2, 1.5.8, 1.6.3, 1.7

In the event of any alteration which has not been approved by us being made to any device as designated below, this statement shall thereby be made invalid.

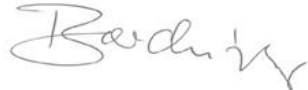
Device	Applicator
Type	HQI 4034
Applied EU Regulations	Applied Standards
Directive 2006/42/EC on machinery	EN ISO 12100:2010
	EN ISO 13849-1:2015
	EN 62368-1: 2014/AC:2015
Other Relevant Directives	
<ul style="list-style-type: none"> • Directive 2014/30/EU relating to electromagnetic compatibility • Directive 2011/65/EU on the restriction of the use of certain hazardous substances in electrical and electronic equipment 	
Person authorised to compile the technical file	Marcel Michalski Am Unterwege 18/20 99610 Sömmerda
Signed for, and on behalf of the Manufacturer	Karlsruhe, 07.01.2026
cab Produkttechnik GmbH & Co KG Wilhelm-Schickard-Str. 14 D-76131 Karlsruhe	 Klaus Bardutzky Managing Director

The product must not be put into service until the final machinery into which it is to be incorporated has been declared in conformity with the provisions of the Directive on machinery.

The documents according annex VII part B from the incomplete machinery are created and will commit to state agencies on request in electronic kinds.

7.2 EU Declaration of Conformity



cab Produkttechnik
GmbH & Co KG
Wilhelm-Schickard-Str. 14
D-76131 Karlsruhe
Germany

EU Declaration of Conformity

We declare herewith that the following device as a result of design, construction and the version put in circulation complies with the relevant fundamental regulations of the EU Rules for Safety and Health. In the event of any alteration which has not been approved by us being made to any device as designated below, this statement shall thereby be made invalid.

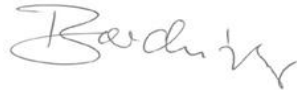
Device	Applicator
Type	HQI 4034
Applied EU Regulations	Applied Standards
Directive 2014/30/EU relating to electromagnetic compatibility	EN 55032:2015+A11:2020
	EN 55035:2017+A11:2020
	EN 61000-6-2:2005/AC:2005
Directive 2011/65/EU on the restriction of the use of certain hazardous substances in electrical and electronic equipment	EN IEC 63000:2018
Commission delegated directive (EU) 2015/863 amending Annex II to Directive 2011/65/EU of the European Parliament and of the Council as regards the list of restricted substances	
Signed for, and on behalf of the Manufacturer	Karlsruhe, 07.01.2026
cab Produkttechnik GmbH & Co KG Wilhelm-Schickard-Str. 14 D-76131 Karlsruhe	
	Klaus Bardutzky Managing Director