

## Assembly Instructions

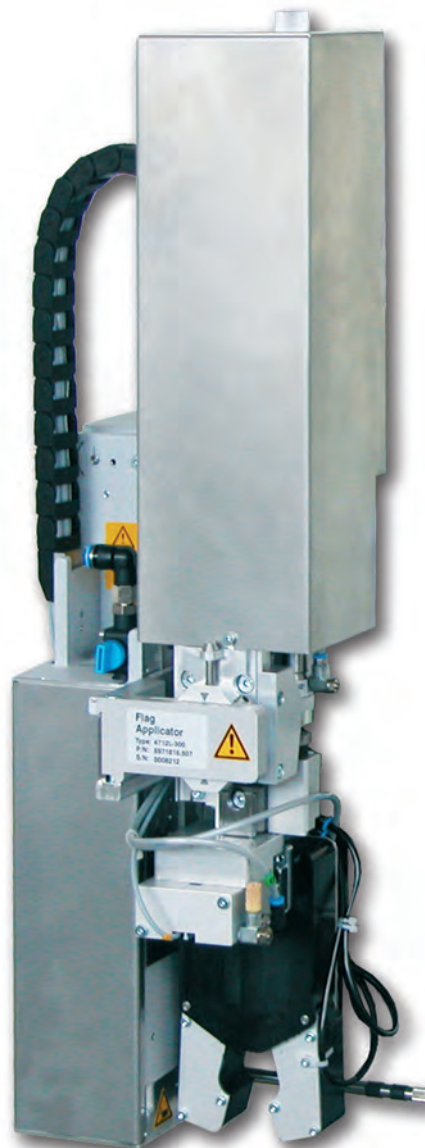

Flag Applicator

# HQ 4712

Family	Type
Flag Applicator	HQ 4712L-300

**Edition:** 02/2026 - Part No. 9004085

**Copyright**

This documentation as well as translation hereof are property of cab Produkttechnik GmbH & Co. KG.

The replication, conversion, duplication or divulgement of the whole manual or parts of it for other intentions than its original intended purpose demand the previous written authorization by cab.

**Editor**

Regarding questions or comments please contact cab Produkttechnik GmbH & Co. KG.

**Topicality**

Due to the constant further development of our products discrepancies between documentation and products can occur.

Please check [www.cab.de](http://www.cab.de) for the latest update.

**Terms and conditions**

Deliveries and performances are effected under the General conditions of sale of cab.

---

Germany  
**cab Produkttechnik GmbH & Co KG**  
Karlsruhe  
Phone +49 721 6626 0  
[www.cab.de](http://www.cab.de)

USA  
**cab Technology, Inc.**  
Chelmsford, MA  
Phone +1 978 250 8321  
[www.cab.de/us](http://www.cab.de/us)

Taiwan  
**cab Technology Co., Ltd.**  
Taipei  
Phone +886 (02) 8227 3966  
[www.cab.de/tw](http://www.cab.de/tw)

Singapore  
**cab Singapore Pte. Ltd.**  
Singapore  
Phone +65 6931 9099  
[www.cab.de/en](http://www.cab.de/en)

France  
**cab Technologies S.à.r.l.**  
Niedermodern  
Phone +33 388 722501  
[www.cab.de/fr](http://www.cab.de/fr)

Mexico  
**cab Technology, Inc.**  
Juárez  
Phone +52 656 682 4301  
[www.cab.de/es](http://www.cab.de/es)

China  
**cab (Shanghai) Trading Co., Ltd.**  
Shanghai  
Phone +86 (021) 6236 3161  
[www.cab.de/cn](http://www.cab.de/cn)

South Africa  
**cab Technology (Pty) Ltd.**  
Randburg  
Phone +27 11 886 3580  
[www.cab.de/za](http://www.cab.de/za)

<b>1</b>	<b>Introduction .....</b>	<b>4</b>
1.1	Instructions.....	4
1.2	Intended Use.....	4
1.3	Safety Instructions.....	4
1.4	Safety Markings .....	5
1.5	Environment.....	5
<b>2</b>	<b>Product Description.....</b>	<b>6</b>
2.1	Important Features.....	6
2.2	Technical Data.....	6
2.3	Product Overview.....	7
2.4	Contents of Delivery.....	8
<b>3</b>	<b>Implementing.....</b>	<b>9</b>
3.1	Required Space .....	9
3.2	Tools for the implementing .....	9
3.3	Mounting the Applicator.....	10
3.4	Compressed Air Connection .....	11
3.5	Test motion sequence and sensors.....	11
3.6	Mounting and Demounting the Cover .....	12
3.7	Releasing the Transport lock.....	12
3.8	Mounting the Suction Pads .....	13
3.9	Mounting the Blow Tube.....	13
3.10	Preparing the Tamp Assembly for Adjustments.....	14
3.11	Adjusting the Pad.....	15
3.11.1	Moving the Pad in Y-Direction .....	16
3.11.2	Moving the Pad in Z-Direction .....	17
3.11.3	Moving the Pad in X-Direction.....	18
3.12	Adjustments to the Blow Tube (Support air).....	19
3.13	Adjusting the Vacuum .....	20
3.14	Alignment of the Product to the Applicator .....	21
3.15	Setting the Application Height .....	22
<b>4</b>	<b>Operation .....</b>	<b>23</b>
4.1	Test Mode without a Print Job.....	23
4.2	Test Mode with a Print Job.....	23
4.3	Standard Operation.....	24
4.4	Cleaning.....	24
<b>5</b>	<b>Configuration.....</b>	<b>25</b>
5.1	Setting the Hand-over Position .....	25
5.2	Activation of Peel-off Mode .....	25
5.3	Settings in the Printer Menu.....	26
5.4	Special JScript Commands .....	27
<b>6</b>	<b>Error Messages .....</b>	<b>28</b>
6.1	Error Messages of the Printer .....	28
6.2	Error messages of the applicator .....	28
<b>7</b>	<b>Licenses.....</b>	<b>30</b>
7.1	Declaration of Incorporation .....	30
7.2	EU Declaration of Conformity.....	31

## 1.1 Instructions

Important information and instructions in this documentation are designated as follows:



### Danger!

Draws attention to an exceptionally great, imminent danger to your health or life due to hazardous voltages.



### Danger!

Draws attention to a danger with high risk which, if not avoided, may result in death or serious injury.



### Warning!

Draws attention to a danger with medium risk which, if not avoided, may result in death or serious injury.



### Caution!

Draws attention to a danger with low risk which, if not avoided, may result in minor or moderate injury.



### Attention!

Draws attention to potential risks of property damage or loss of quality.



### Note!

Advice to make work routine easier or on important steps to be carried out.



### Environment!

Gives you tips on protecting the environment.



Handling instruction



Reference to section, position, illustration number or document.



Option (accessories, peripheral equipment, special fittings).

*Time*

Information in the display.

## 1.2 Intended Use

- The device is manufactured in accordance with the current technological status and the recognized safety rules. However, danger to life and limb of the user or third parties and/or damage to the device and other tangible assets can arise during use.
- The device may only be used for its intended purpose and if it is in perfect working order, and it must be used with regard to safety and dangers as stated in the manual.
- The device is designed to use on a cab printer of the HERMES Q series. Any other use or use going beyond this shall be regarded as improper use. The manufacturer/supplier shall not be liable for damage resulting from unauthorized use; the user shall bear the risk alone.
- Usage for the intended purpose also includes complying with the manual.



### Note!

The complete and current version of the documentation can be found in the Internet.



## 1.3 Safety Instructions



### Attention!

Initiation, adjustments and changing of parts are to be performed by qualified service personnel only.







### Warning!

This is a class A product. In a domestic environment this product may cause radio interference in which case the user may be required to take adequate measures.

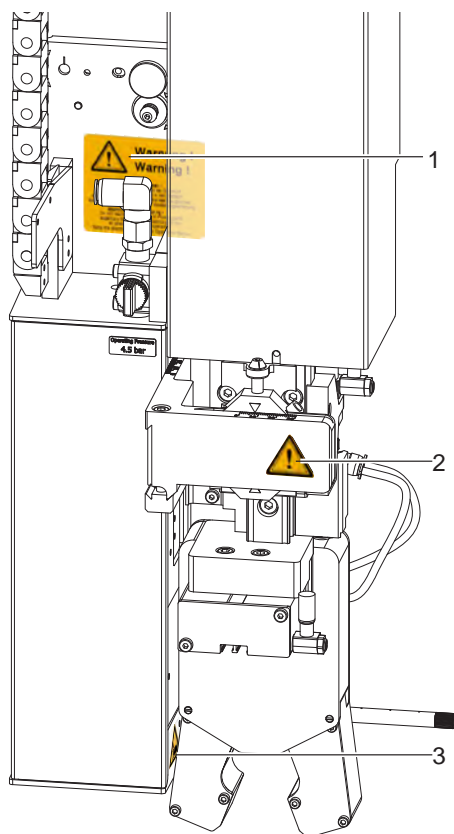
- Before mounting the delivered components disconnect the printer from the power supply and close the shutoff valve of the applicator.
- Only connect the device to other devices which have a protective low voltage.
- Switch off all affected devices (computer, printer, accessories) before connecting or disconnecting.
- In operation, moving parts are easily accessible. This applies especially for the zone, where the pad is moved between the starting and the labelling position. During operation do not reach into that zone and keep long hair, loose clothes, and jewelry distant. Before any manipulations in those areas, close the shutoff valve.
- The device may only be used in a dry environment, do not expose it to moisture (sprays of water, mists, etc.).
- Do not use the device in an explosive atmosphere.
- Do not use the device close to high-voltage power lines.
- Perform only those actions described in this manual. Work going beyond this may only be performed by trained personnel or service technicians.
- Unauthorized interference with electronic modules or their software can cause malfunctions.
- Other unauthorized work on or modifications to the device can also endanger operational safety.
- Always have service work done in a qualified workshop, where the personnel have the technical knowledge and tools required to do the necessary work.
- There are various warning stickers on the device. They draw your attention to dangers. Warning stickers must therefore not be removed, as then you and other people cannot be aware of dangers and may be injured.

### 1.4 Safety Markings



- 1:  Risk of injuries by moving parts!
- 2:  The cylinder is under pressure also if the printer is switched off. Possibility of residual energy!
- 3:  Danger of crushing hands and fingers by the moving pad!

**Attention!**  
 Never remove or cover safety markings!  
 Replace it in case of damage!

Fig. 1 Safety marking

### 1.5 Environment



Obsolete devices contain valuable recyclable materials that should be sent for recycling.

- ▶ Send to suitable collection points, separately from residual waste.

The modular construction of the applicator enables it to be easily disassembled into its component parts.

- ▶ Send the parts for recycling.

### 2.1 Important Features

- The support air and the vacuum as well as the speed of the cylinder are adjustable. That way the applicator can be adapted to different label materials and sizes.
- For operation within a system the I/O interface of the printer can be used.

### 2.2 Technical Data

Flag applicator		HQ 4712
State of a product at the moment a label is applied	at rest	■
Label applications		from the top, from below, from the side rotated vertically: 0-180° clockwise (request in case of other rotations)
Product heights	uniform	■
Distance of a product to the bottom of the unit using a cylinder stroke of 300	at least mm	70
	up to mm	260
Depth of pliers immersing	mm	55
Offset P	up to mm	1.0 <sup>2)</sup>
Weight of applicator	packaging excluded kg	8
Consumption of power	W max.	15
Compressed air	bar	4.5
Cycle rate, printing and applying only <sup>3)</sup>	labels/min approx.	15

<sup>1)</sup> Processing labels 50 to 58 mm wide requires a spacer.  
<sup>2)</sup> depending from the quality of a label  
<sup>3)</sup> calculated using a print speed of 100 mm/s  
<sup>4)</sup> Flag on product requires >60 mm clearance on one side without components, bend or step

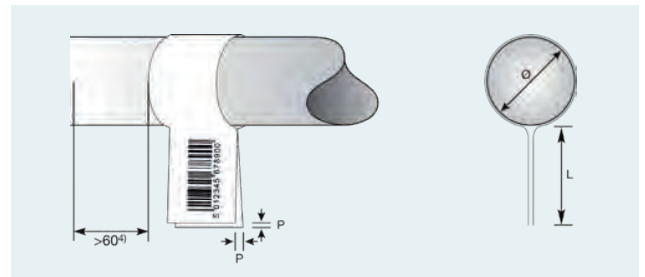
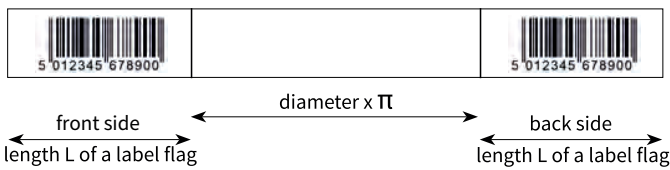

Transfer module		Form pad	
		4712 L 300	
Label widths	HERMES Q4L/Q4.3L	mm	50 <sup>1)</sup> -100
Label heights		mm	10-50
Diameter		mm	3-16

Table 1 Technical data

2.3 Product Overview

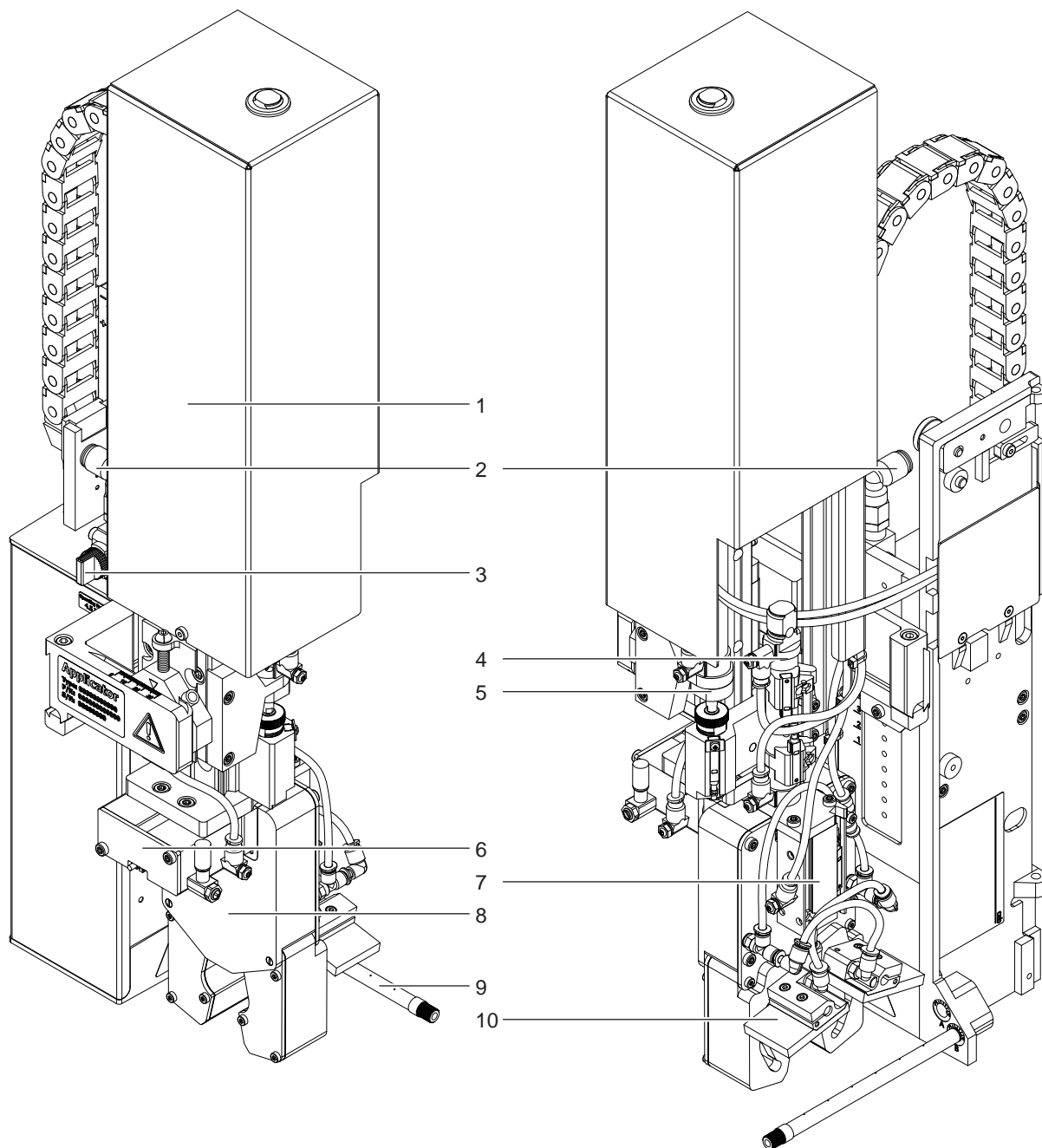
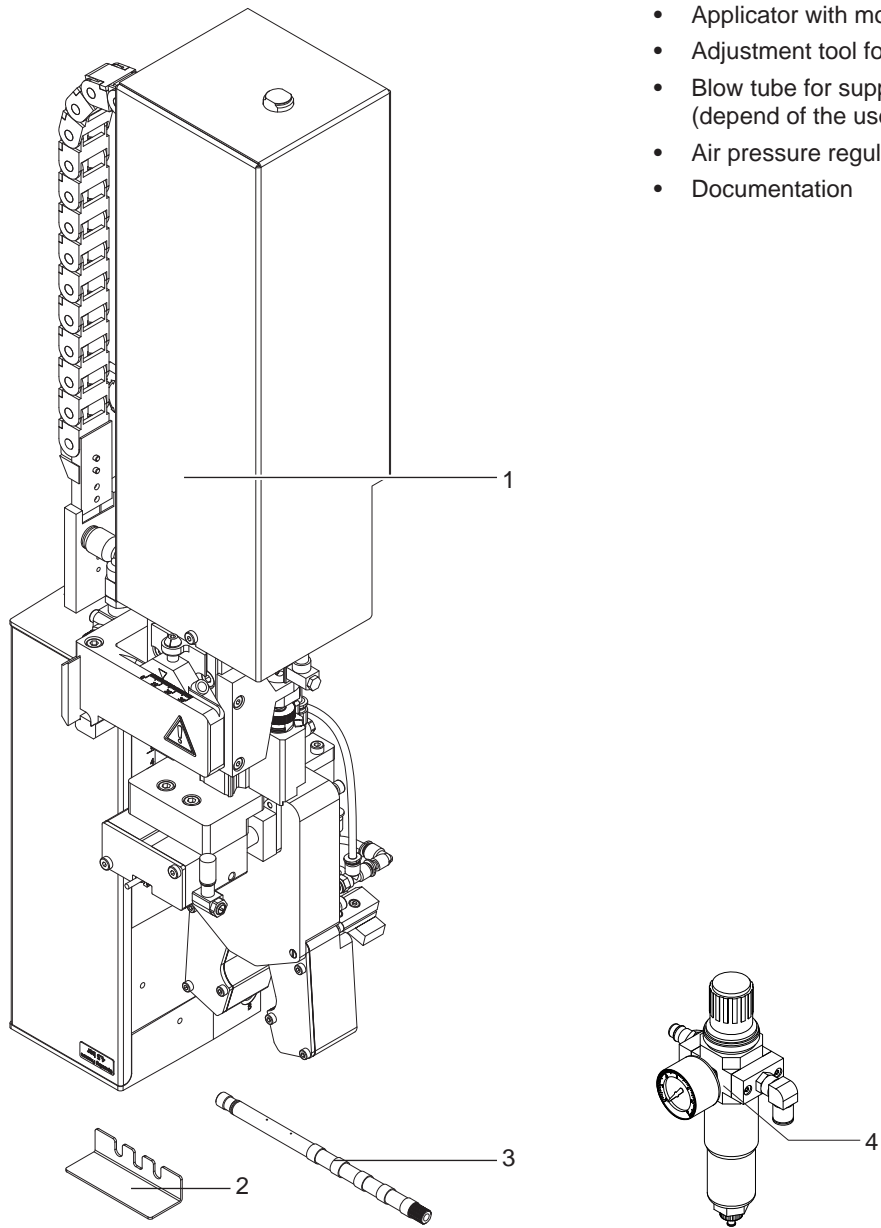

Fig. 2 Product Overview

- |                                       |                             |
|---------------------------------------|-----------------------------|
| 1 Cover                               | 6 Cylinder peel position    |
| 2 Compressed air connector            | 7 Compact cylinder Pliers   |
| 3 Shutoff valve                       | 8 Tamp group                |
| 4 Short stroke cylinder - tamp / flag | 9 Blow tube for support air |
| 5 Main stroke cylinder                | 10 Pair of tamps            |

## 2.4 Contents of Delivery



- Applicator with mounted tamp assembly (1)
- Adjustment tool for the tamps (2)
- Blow tube for support air (3)  
(depend of the used printer)
- Air pressure regulation unit (4) as ordered
- Documentation

Fig. 3 Content of Delivery

**Note!**

Please keep the original packaging in case the applicator must be returned.

**Attention!**

The device and printing materials will be damaged by moisture and wetness.

- ▶ Only set up the label printer with applicator in dry locations protected from moisture and splashes.

3.1 Required Space

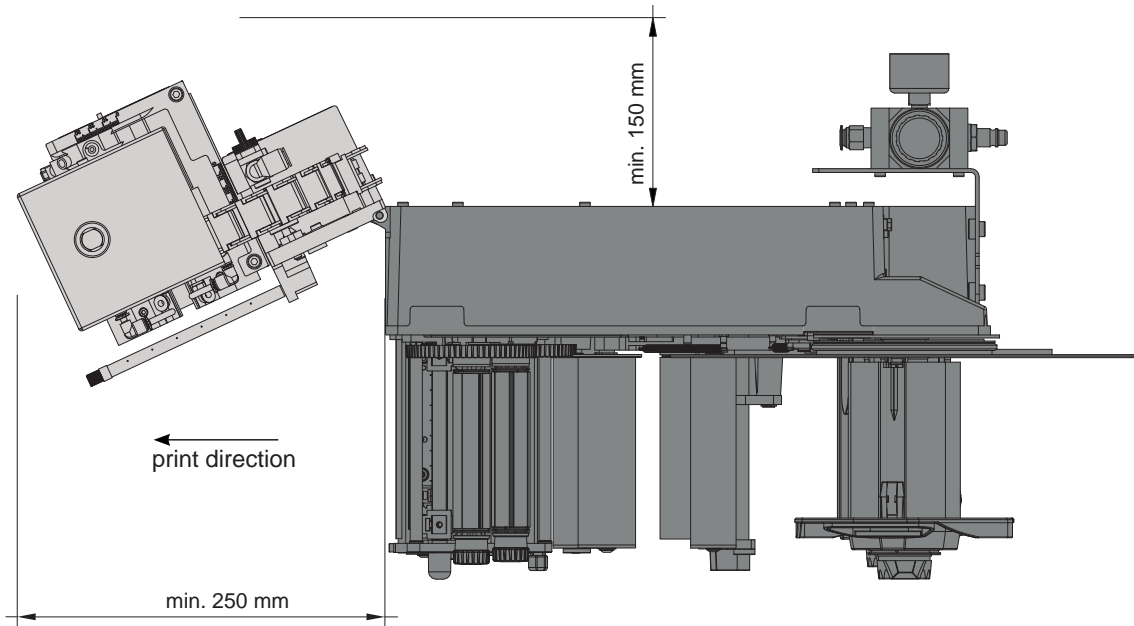

Fig. 4 Disengaging or pivoting the applicator

3.2 Tools for the implementing







Screwdriver with parallel blade	2.5		To adjust the throttle valves and product sensor
Hexagon key L-wrench	0.8		To adjust the sensors (in contents of delivery)
	2.5		For matched norm parts (in contents of delivery)
	4		Pad adjustments Changing pad
Flat-round nose	straight		To mount/dismount tubes
	angled		
Open spanner	SW 5.5 90°		To change the pliers aperture
	SW 8		To change the throttle valves
	SW 13		Setting the spring power on the adapter bolt
	SW20		Changing the cylinder
Adjustment tool for the tamps	cab part No.: 597285		Mounting the tamps

Table 2 Tools

### 3.3 Mounting the Applicator

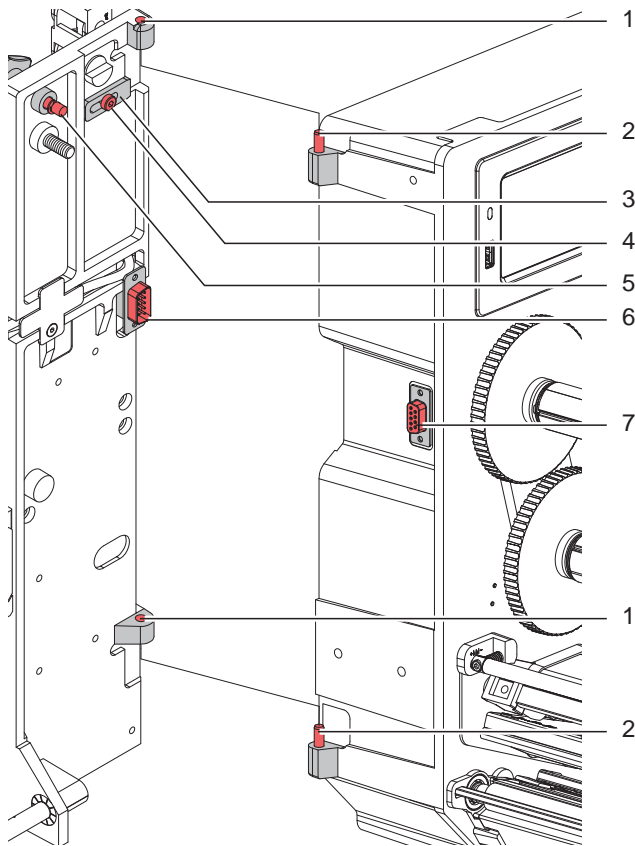

Fig. 5 Mounting applicator on printer



#### Attention!

Initiation, adjustments and changing of parts is only for qualified service personal only.

▷ Service Manual

#### Mount the applicator

1. Hang the applicator with the female part of hinges (1) at the printer mounted hinges parts (2).
2. Connect SUB-D 15 male connector (6) to the female connector (7) of the printer.
3. To prevent the applicator from slipping out of the hinges loosen screw (4) and move the locking plate (3) under the hinges and tighten screw (4).
4. Swing the applicator to the printer and tighten the thumbscrew (5).

For cleaning the applicator and printer it's sometime necessary to turn away or/and dismount the applicator. Don't change the adjustments of setting screws, throttle valves or other.

#### Turn away/Dismount the applicator

5. To turn away the applicator loosen thumbscrew (5) and swing the applicator aside.
6. Disconnect SUB-D 15 male connector (6) to the female connector (7) of the printer and the compressed air supply.
7. Loosen screw (4) and move off the locking plate (3) from the hinges.
8. Lift the applicator upward.

## 3.4 Compressed Air Connection

**Attention!**

Adjustments and functionality control were done with a compressed air value of 4.5 bar.  
The applicator's operating range is between 4.0 and 6.0 bar.

**Warning!**

When connecting the applicator to compressed air it is considered "IN USE!" Cylinder motion is possible!

► Do not reach into the zone of the moving pad and keep long hair, loose clothes, and jewelry away.

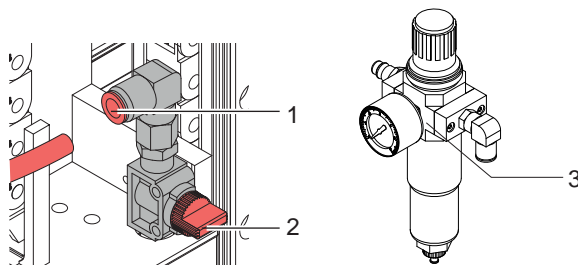

1. Check that the stop valve (2) is closed as illustrated.
2. Attach compressed air to connector (1).
3. Open the stop valve (2) by turning it into the direction of air flow.
4. Switch on the printer via the power switch.

A pressure regulation unit (3) must be connected upstream to stabilize the compressed air supply.

Fig. 6 Compressed air connection

**Note!**

If the pad is not in the starting position when the printer is switched on an error message will appear on the display.

Press the continue button on the printer to cancel the error state. The applicator will move into the start position and is ready for work.

**Note!**

Only mount the air pressure regulation unit as illustrated otherwise the functionality of the air-water separator cannot be guaranteed.

## 3.5 Test motion sequence and sensors

**Note!**

If the pad is not in the starting position when the printer is switched on an error message will appear on the display.

Press the continue button on the printer to cancel the error state. The applicator will move into the start position and is ready for work.

Der Applicator is ready for use.

No error message may be displayed in the basic position and the LEDs on all sensors light up except for the sensor end position of the lifting cylinder of the stamp assembly (Marker No.: 4).

By repeatedly pressing the button , the motion sequence of the applicator is run through.

### 3.6 Mounting and Demounting the Cover

To initialize the applicator or perform adjustments it is required to remove the cover. Once content with the changes reattach the cover.



#### Warning!

It is only permitted to use the applicator with a mounted cover (2).

Only in the case of servicing, adjustments and maintenance may the cover be removed.

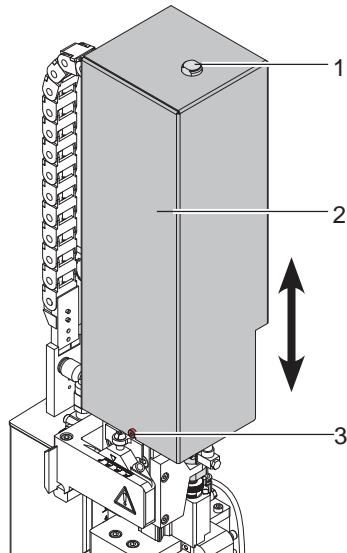

Fig. 7 Cover

1. Loosen the screw (3).
2. Lift off the cover upward (2).
3. Once the service or maintenance has been completed lower the cover over the cylinder.
4. Guide cylinder (1) through the hole in the cover (2).
5. Tighten the screw (3) to fix the cover (2) in place.

### 3.7 Releasing the Transport Lock

Before the applicators are delivered, a transport lock (4) is mounted on the rod (1).

For the labeling operation, the transport lock (4) is pushed onto the stopper (2).

The stopper (2) brakes the lifting movement and triggers the flag formation.

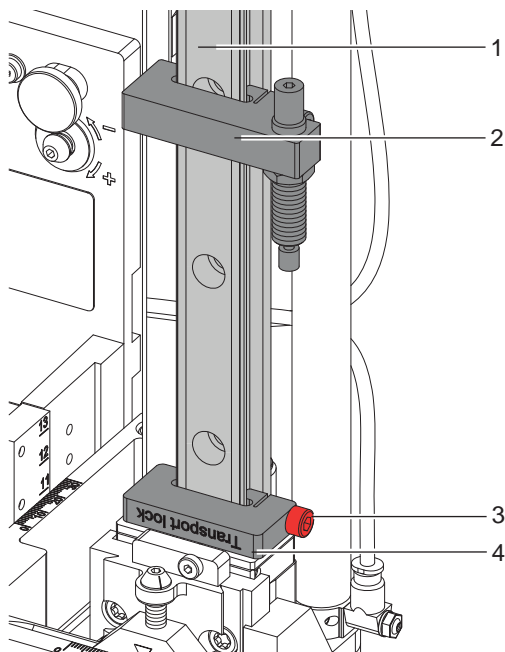

Fig. 8 Transport Lock

#### Releasing the transport lock

1. Loosen the screw (3) of the transport lock (2).
2. Move the transport lock (4) on the rod (1) to the stopper (2).
3. Tighten the screw (3) of the transport lock (2) to fix the position.

If the position of the stopper (2) is changed to change the application height, the transport lock (4) must also be moved.

▷ „3.15 Setting the Application Height“

3.8 Mounting the Suction Pads

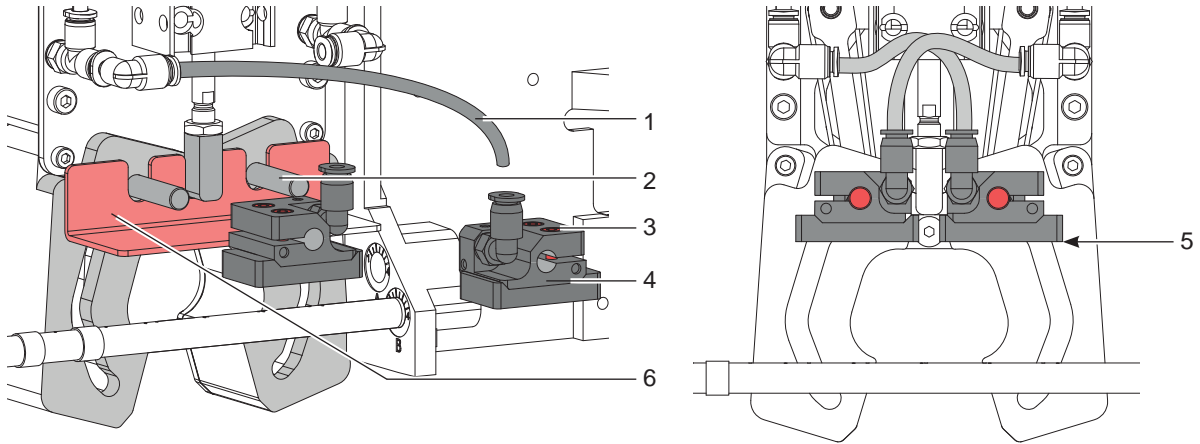



Fig. 9 Mounting the suction pads

1. Loosen screws (3).
2. Use the adjusting tool (6) included (cab serial No.: 5972857) as shown in the picture to adjust the suction plates.
3. Slide each suction plate (4) over the corresponding driving pin (2) to the adjusting tool (6).  
Mount the suction plates (4) so that the L connectors (hose connections) are accessible from the front.
4. Tighten screws (3).
5. Remove adjustment tool (6) downwards.  
The lower surfaces must now be aligned at an angle of 0 ° and at a height to each other.
6. By repeatedly pressing the button , the motion sequence of the applicator is run through.  
Then check the alignment of the tamps and adjust if necessary.

3.9 Mounting the Blow Tube

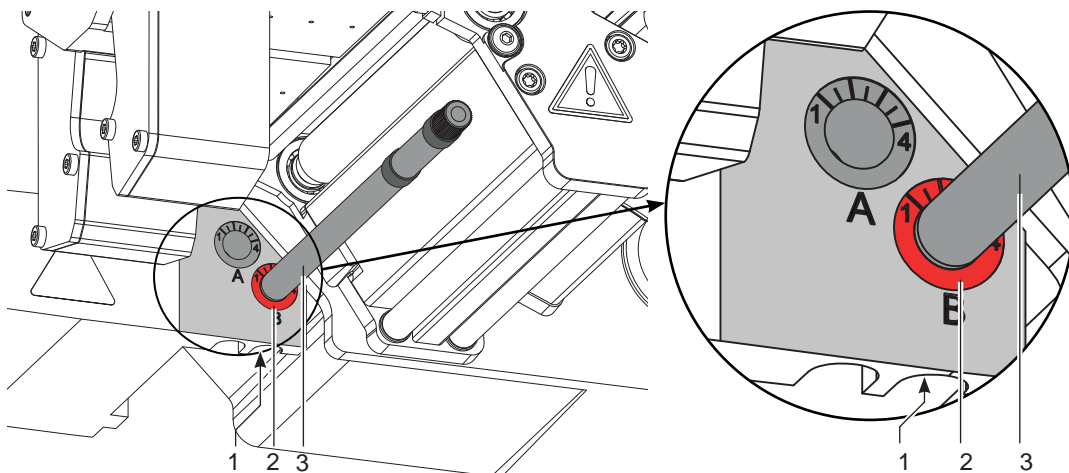

Fig. 10 Mounting the blow tube

The blow tube (3) can be rotated around its axis. By this principle the direction of the compressed air can be optimized.

1. Loosen the screw (1).
2. Insert the blow tube (3) as far as possible into the provided slot B (2).
3. Tighten the screw (1) to ensure the blow tube stays in place.  
▷ „3.12 Adjustments to the Blow Tube and Support Air“.



### Attention!

All pneumatic settings have been made and optimized in the factory. Settings are only when changing corresponding components. according to the commissioning test report included in the scope of delivery. Settings must then be made by using the test report. The test report is part of the scope of delivery.

▷ Service Manual

Changes can be made to the setting of the strength of the support air and the vacuum in order to adapt it to the label material used.

## 3.10 Preparing the Tamp Assembly for Adjustments

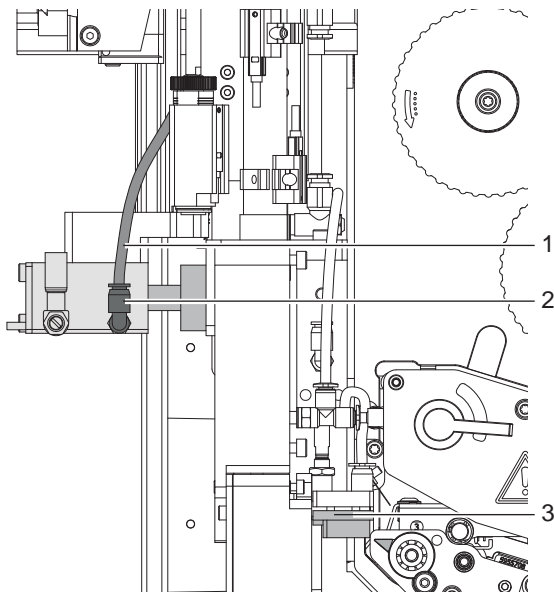

Fig. 11 Preparing the tamp assembly for adjustments

1. Pull off the tube (1) from the L-connector (2) on the horizontal cylinder.
2. Align the suction pads (3) to the dispense edge of the printer ▷ „3.11 Adjusting the Pad“.
3. Connect the tube (1) to the L-connector (2).

3.11 Adjusting the Pad

For the perfect application of labels it is necessary that the pad is placed precisely above the dispensed label.

**Aligning the pad parallel to the dispensing plate**

The edge of the pad should be positioned parallel to the dispensing plate of the printer in order to position the label exactly on the pad.

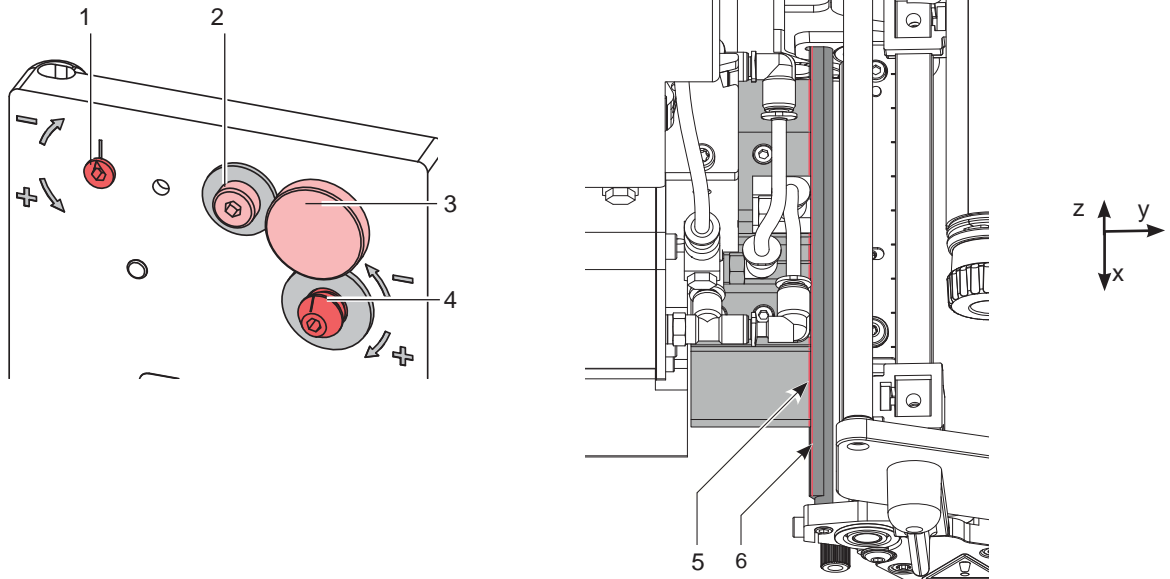
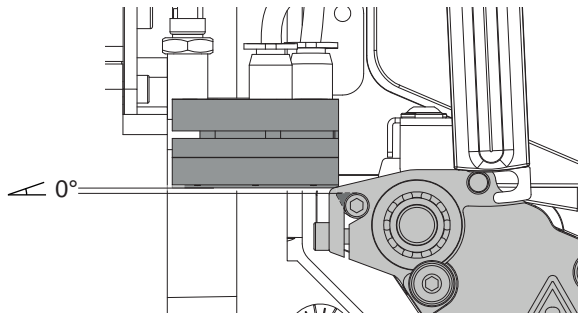

Fig. 12 Aligning the pad to the dispensing plate

1. Loosen the knurled screw (3) and the set screw (4).
2. Screw in the knurled screw (3) until the stamp edges (5) are aligned parallel to the dispensing edge (6) of the printer.
3. Tighten the set screw (4) until it touches the printer.

**Aligning the pad at an angle to the dispensing plate**



4. If the angle between the tamp surface and the dispensing edge - support surface is not 0 ° loosen screw (2).
5. Correct the angle of attack by turning the eccentric (1).
6. Tighten screw (2).

## 3.11.1 Moving the Pad in Y-Direction

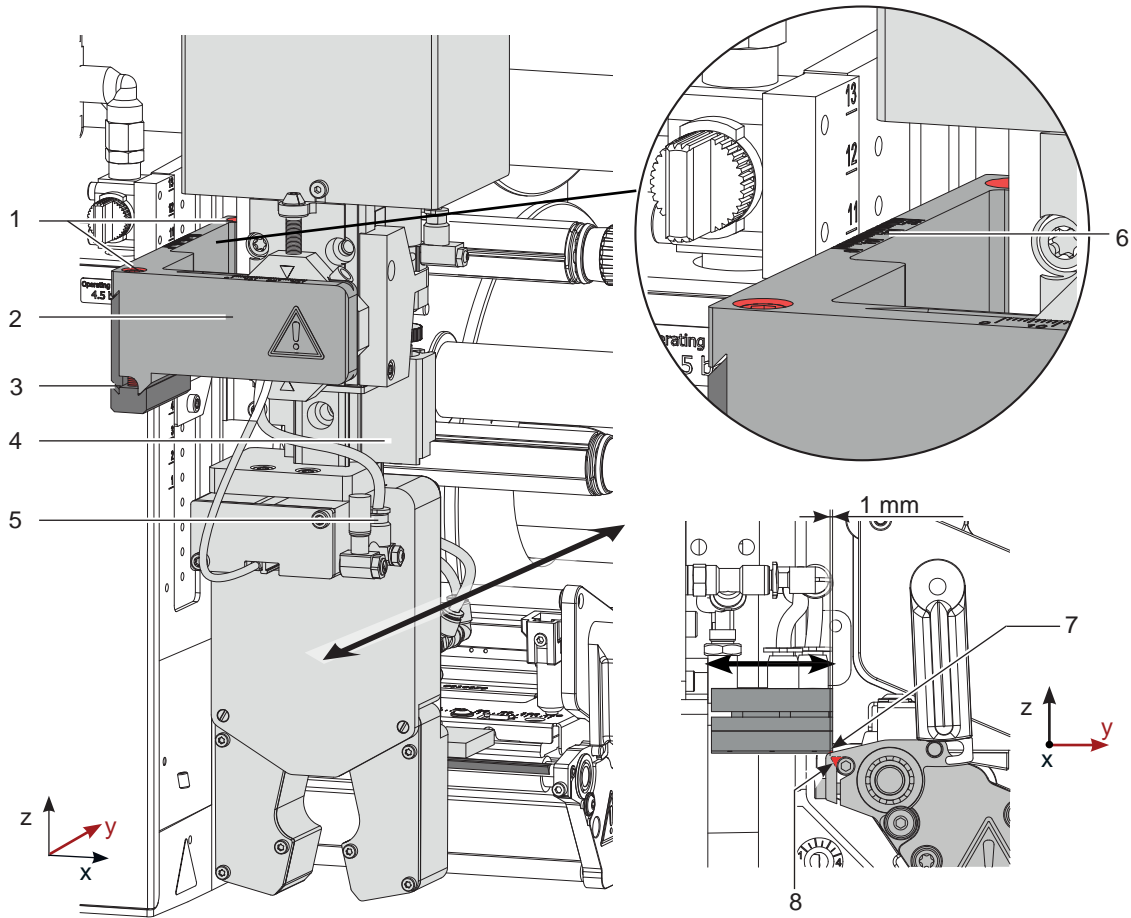

Fig. 13 Displacement in the Y direction

**Displacement in the Y direction (printing direction)**

1. Switch off the compressed air and pull the tube out of the throttle valve (5). The cylinder extends by spring force and is in the label transfer position.
2. Loosen screws (1) on the cross beam (2).
3. Move cylinder assembly (4) with the pad and crossbeam (2) along the guiding rail (3) that the distance from the edge of the pad (7) to the edge of the dispensing plate (8) of the printer is approximately 1 mm.  
Orientation: Graduation (6)
4. Tighten screws (1).
5. Put the tube back into the throttle valve (5) and switch on the compressed air.

## 3.11.2 Moving the Pad in Z-Direction

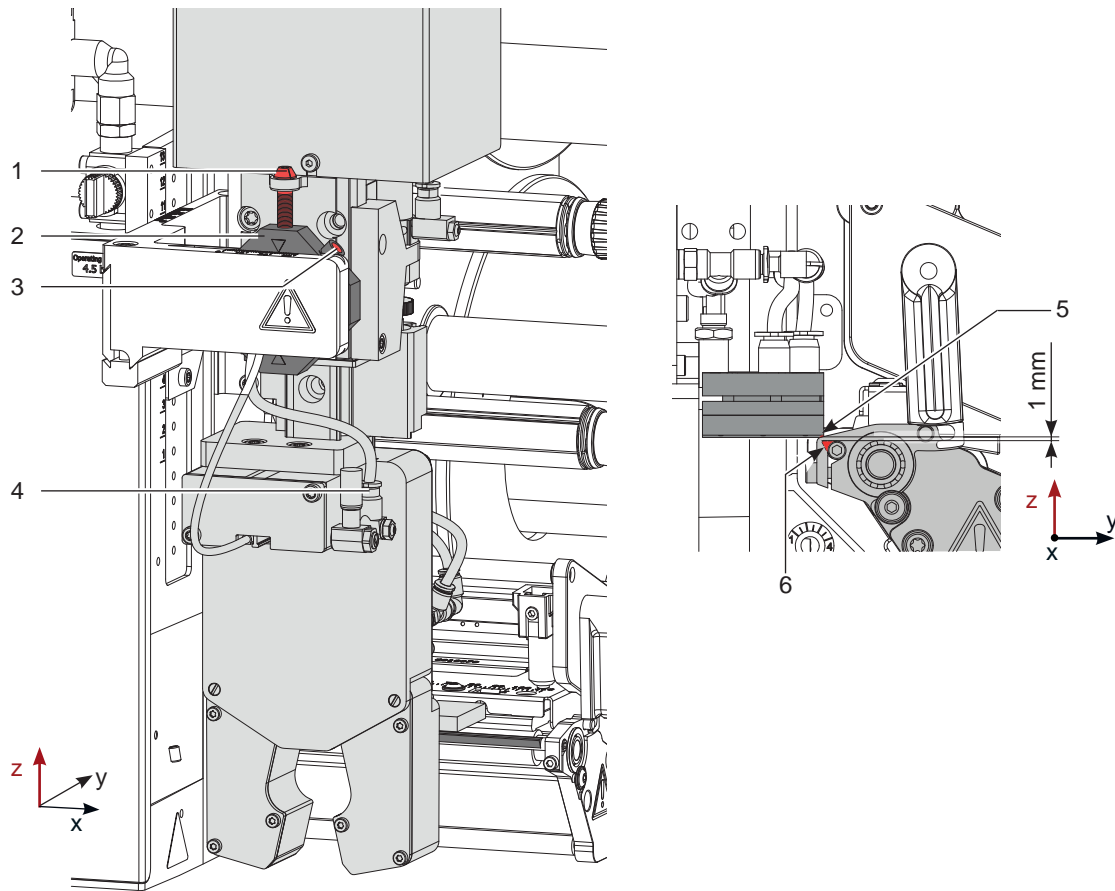

Fig. 14 Displacement in the Z direction

**Displacement in the Z direction (Height)**

1. Switch off the compressed air and pull the tube out of the throttle valve (4). The cylinder extends by spring force and is in the label transfer position.
2. Loosen screw (3) on the binder (2).
3. Turn the setting screw (1) so that the bottom side of the pad is 1 mm over the top of the dispensing plate (6) of the printer.
4. Tighten screw (3).
5. Put the tube back into the throttle valve (4) and switch on the compressed air.

3.11.3 Moving the Pad in X-Direction

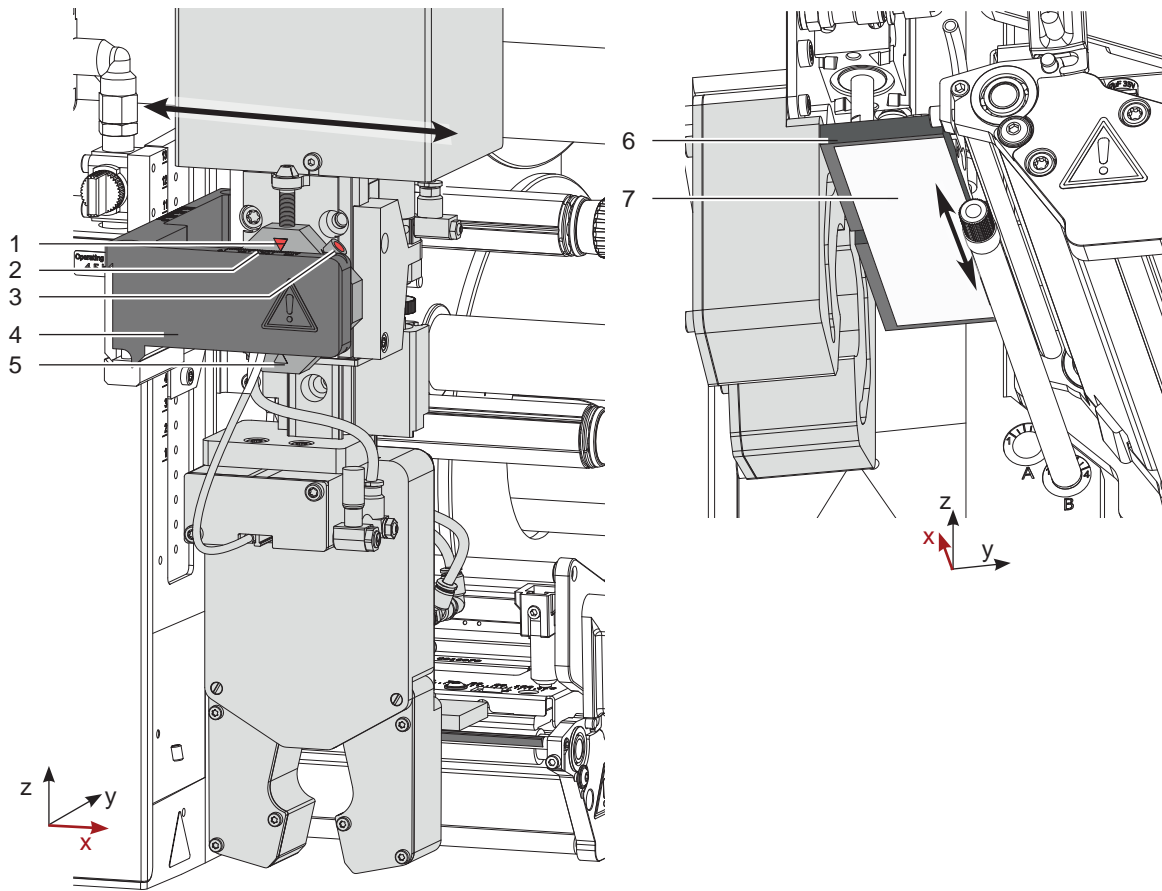

Fig. 15 Displacement in the Y direction

**Displacement in the X direction (Side)**

1. Loosen screw (3) on the binder (5).
2. Move cylinder assembly with the pad along the crossbeam (4) so that the dispensed label (7) is aligned centrally to the pad (6). As reference use the provided graduation/ruler on the crossbeam. Orientation: Graduation (2) and Marking (1)
3. Tighten screw (3).

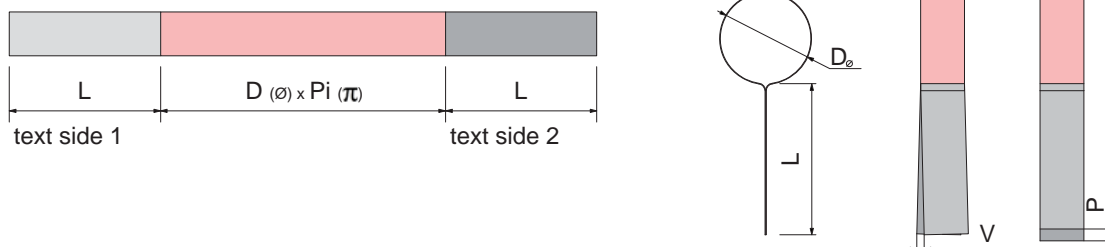

Fig. 16 Label parameter

A misalignment of the stamp to the printer can be recognized by the increase in the length offset P and / or the bevel V (side offset)

- With bevel V (side offset) the parallelism of the stamp to the dispensing edge of the printer must be set.
- With length offset P, the position of the punch in the X direction must be set.

### 3.12 Adjustments to the Blow Tube and Support Air

For optimal support during the acquisition of the label of the applicator the support air is to be set up so that it is free of turbulence and evenly pushes the label against the pad.

The rubber rings must be removed from the holes that lie across the width of the label.

**The default air pressure value is set to 2 bar.**



**Note!**

**When changing the used printer type (2", 4" or 6") the respective blow tube is to be used. With the correct blow tube the quantity of blow holes used and the air pressure and blow tube alignment should be adjusted respectively.**

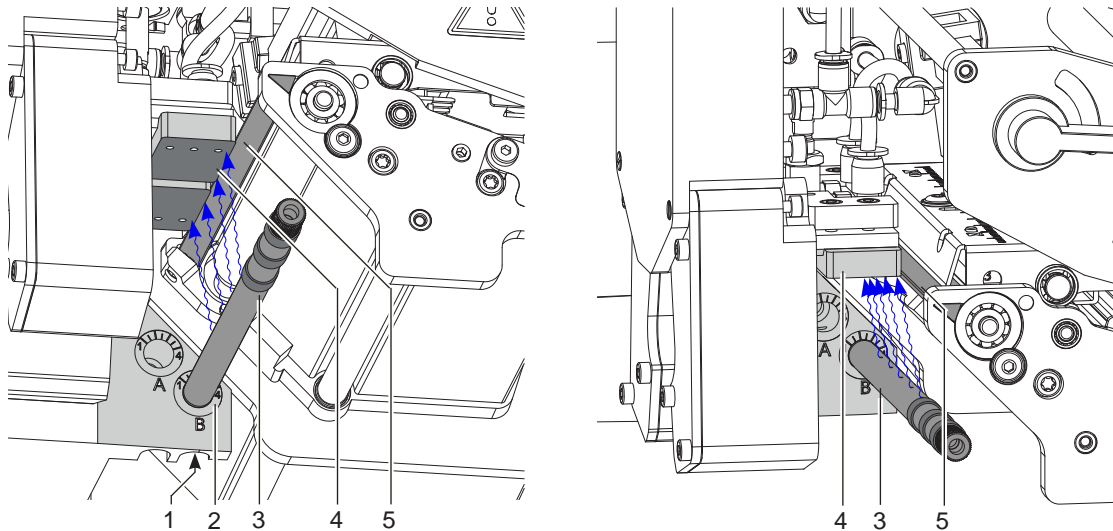

Fig. 17 Adjustment to the blow tube

The blow tube (3) for the relative air pressure can be turned on its own axis to optimize the support for the label acquisition.

1. Loosen screw (1).
2. Insert the blow tube (1) into the blow tube-slot B (2).  
Turn the blow tube so that the airflow supports the label from the dispensing plate (5) to the pad (4).
  - For smaller labels turn the holes of the blow tube into the direction of the dispensing plate (4).
  - For larger labels guide a stronger airflow away from the dispensing plate (5) toward the pad (4).  
Better orientation can be obtained by using the indicator at the base of the blow tube.
3. Tighten screw (1).

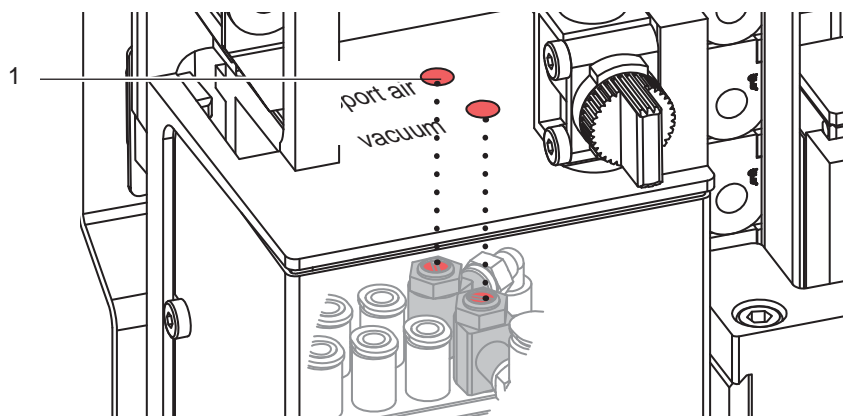

Fig. 18 Throttle valve for support air

The force of the compressed air can be varied via the throttle valve (1) to improve the blowing onto the label.

- ▶ To strengthen the support air turn the throttle valve (1) counter-clockwise.

### 3.13 Adjusting the Vacuum

Via the negative pressure the label is fixed to the applicator. This vacuum needs to be strong enough to hold the label and cover all suction apertures. It may not be strong enough to hinder the transport of the from the printer to the applicator. This is dependent on the label material used.

**The default value of the vacuum is -0.6 bar.**



**Note!**

By adjusting the vacuum it is possible to prevent the label from being applied to the product. If the vacuum is too strong the label will not be released by the pad.

If the vacuum is set too high the advancement of the label can be stopped before it reached the pad properly.

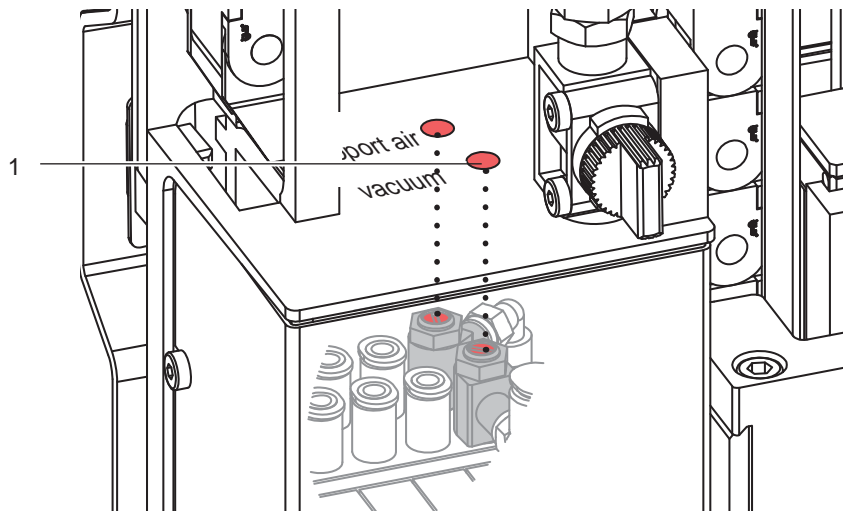

Fig. 19 Vacuum throttle valve

- ▶ Use the throttle valve (1) to ensure that the label is sucked up correctly over its entire surface.
- ▶ To strengthen the vacuum turn the throttle valve setting screw counter-clockwise.

3.14 Alignment of the Product to the Applicator

Depending on the orientation of the applicator to the printer the alignment of the product will take place



**Note!**

For optimal alignment of the product for labeling a fixed uptake of the product is necessary.

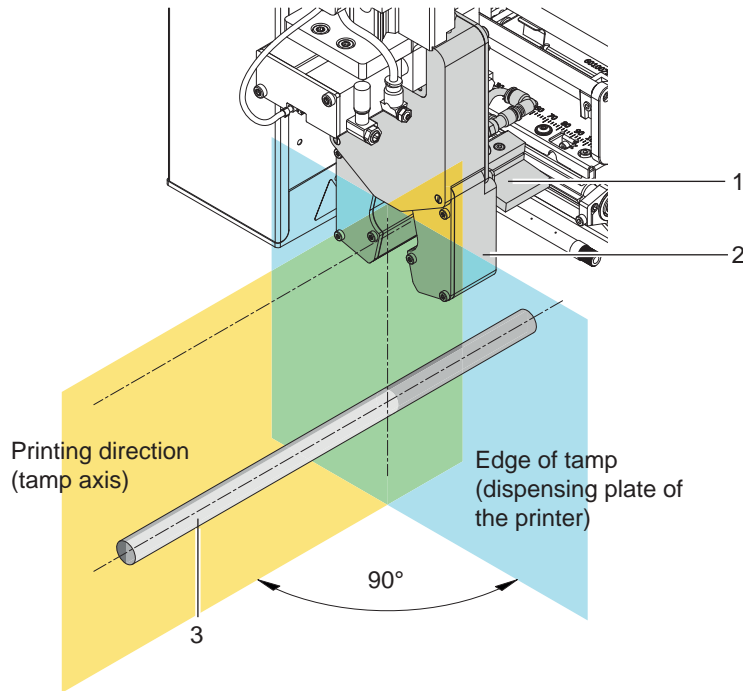

Fig. 20 Alignment of the product to the tamp

The product (3, 5) must be aligned 90° to the edge of the pad (1). Because the pad with the tongs (2) are parallel to the dispensing plate of the printer it can be used for the alignment.

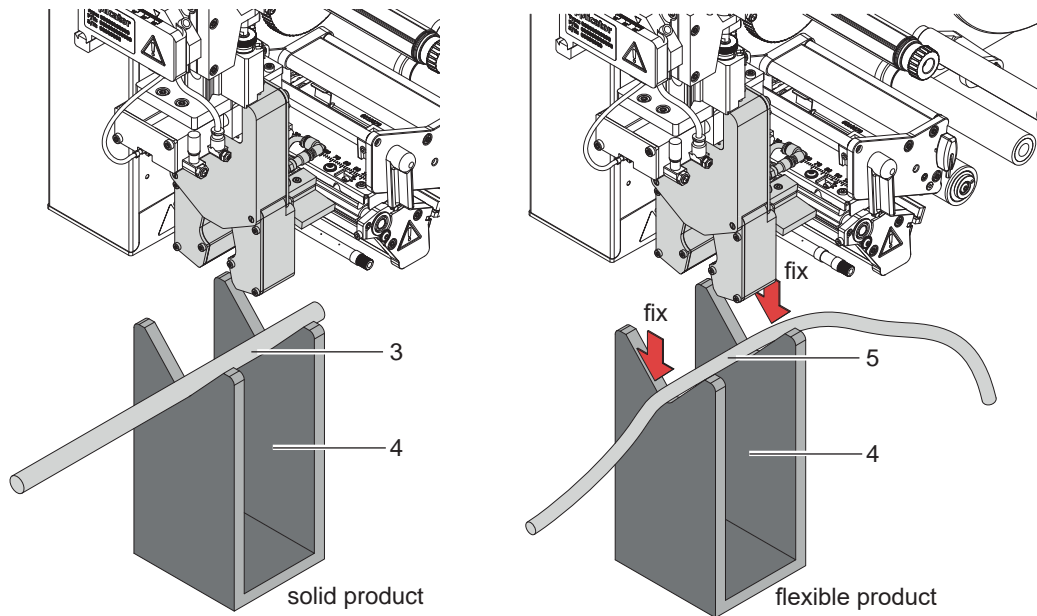

Fig. 21 Examples of simple product uptake

With flexible products (5) both edges must be fixed to prevent the product from moving during the application process.

### 3.15 Setting the Application Height

- ▶ Dismount the cover ▷ „3.6 Mounting and Demounting the Cover“
- ▶ Place the product in the product-holder
- ▶ Switch off the compressed air.
- ▶ Pull the tubes out of the main cylinder Z-direction to be able to move the pliers manually.
- ▶ Move the pliers to the product manually.
- ▶ The upper edge (2) of the tamp assembly should be located directly under the lower edge of the workpiece (1). Design the appropriate bracket.
- ▶ The center of the workpiece (1) must be perpendicular to the closing plane of the two tamps (2).
- ▶ Loosen the screws (8) at the stopper (4) and screws (9) at the transport lock (3). Pull the Stopper (5) and the transport lock (3) all the way down to the slide until the shock absorber is fully pushed in.
- ▶ Tighten screw (8) at the stopper (4) and screw (9) at the transport lock (3).
- ▶ Fine adjustment by turning the shock absorber (6).



#### Attention!

The transport lock and stop must not hit the carriage (7) directly.  
The carriage (7) may only touch the shock absorber (6).

- ▶ Put the tube back into the main cylinder Z-direction.
- ▶ Switch on the compressed air.
- ▶ Mount the cover ▷ „3.6 Mounting and Demounting the Cover“



#### Attention!

The stroke of the main cylinder is braked by the stop with the shock absorber (5), not by the workpiece!

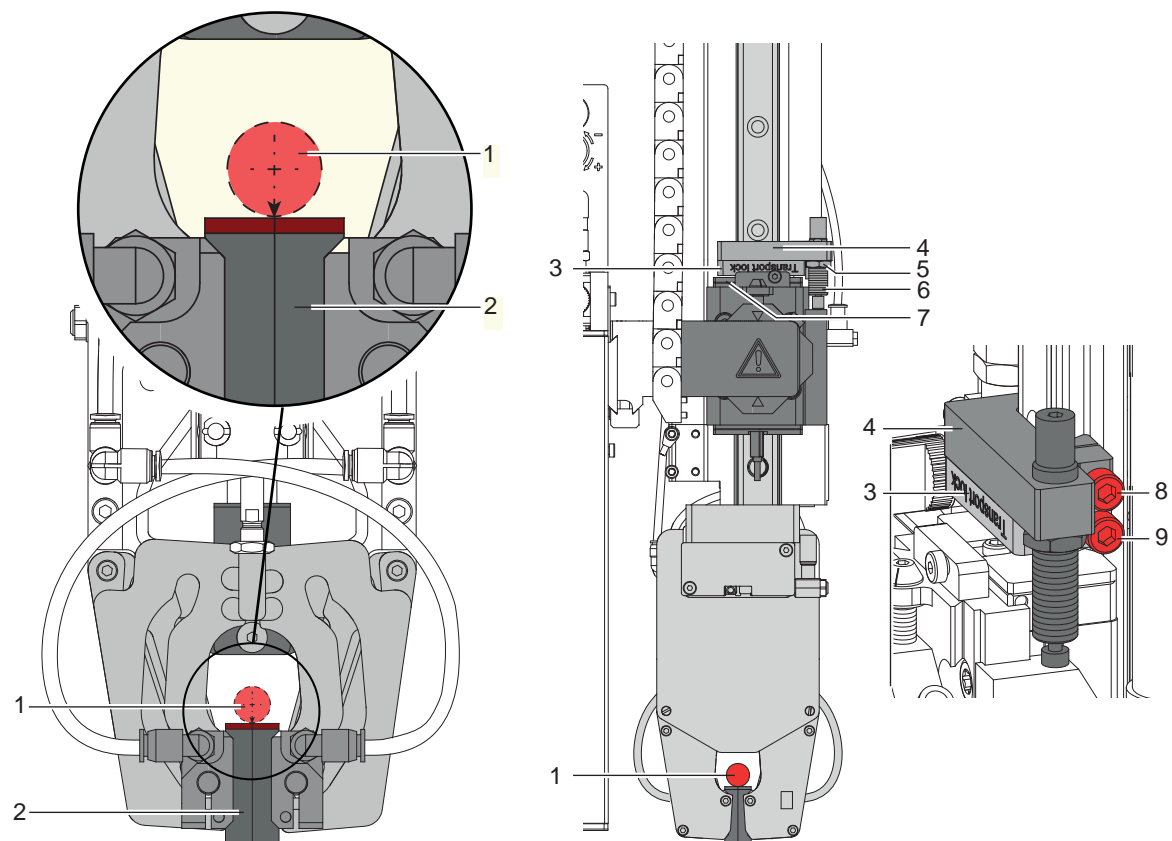

Fig. 22 Adjust the application height

## 4.1 Test Mode without a Print Job

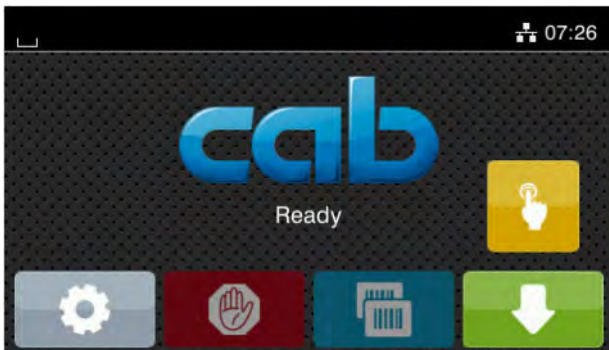





Fig. 23 Display

By alternating between buttons  and  on the display it is possible to simulate the labeling process without an active printing job.

- ▶ Push button . This causes the feed of an empty label. Simultaneously the vacuum of the pad as well as the support air are activated. As soon as the label has securely arrived at the pad the support air is switched off.
- ▶ Push button . When pushing this button the cylinder Z is extended into the labeling position. Reaching the labeling position is signaled by the triggering of the impact sensor. With that signal the vacuum is stopped and the label is applied to the product. With the application of the label the cylinder is contracted back into the starting position.

**Note!**

- ▶ Use the printer configuration to find the best peel-off offset for the initiation.

## 4.2 Test Mode with a Print Job

**Note!**

- ▶ Use the software to find the best peel-off offset for the initiation.

This method allows testing of the labeling process with actual printing data by using the  button.

- ▶ Send a print job.

The test run consists of two steps. Each step is triggered by pressing the  button.

- ▶ Simultaneously, the vacuum at the stamps and the support air are activated. Once the label has been completely gripped by both stamps of the pliers, the support air is deactivated. The pliers move into the labeling position and close.
- ▶ The stamps close, forming a label flag on the product. This is controlled by the locking time parameter.
- ▶ The pliers and stamps open. The *Flag initialisation* parameter allows for a second opening and closing cycle.
- ▶ The pliers and stamps return to their home position.

### 4.3 Standard Operation

- ▶ Check all external connections.
- ▶ Load the material. Ensure that the locking system is locked ▷ "Operator's Manual" of the printer.
- ▶ Open the shutoff valve.



#### Attention!

- ▶ Ensure that the pad is not covered by a label when switching on the printer-applicator system. Otherwise the vacuum sensor may be calibrated incorrectly.

- ▶ Switch on the printer.



#### Note!

If the pad is outside the starting position when the printer-applicator system is switched on the procedure will be interrupted with an error message visible on the display.

Pushing the pause button on the printer will negate the error moving the pad to the starting position. The Applicator is ready for work.

- ▶ Press the  at the printer.  
A synchronization feed is initiated. The processed labels have to be removed manually. After a few seconds the printer carries out a short backfeed to position the front edge of the next label at the printing line.



#### Note!

This synchronization also has to be carried out when the print job has been interrupted with the  button.

Synchronizing is not necessary when the print head was not lifted between print jobs. This also applies if the printer was powered down between print jobs.

- ▶ Start a print job.
- ▶ Start the labelling process via PLC interface.

Error messages during labelling process are shown in the display of the printer ▷ 4 Error Messages.

### 4.4 Cleaning



#### Attention!

- ▶ Never use solvent or abrasive.

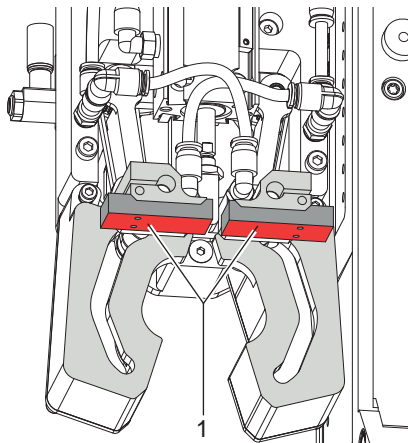

- ▶ Clean the outside surfaces with multi purpose cleaner.
- ▶ Remove dust particles and leftover label pieces with a soft brush and/or vacuum cleaner.
- ▶ The label contact surface (1) requires regular cleaning as the most dirt is deposited here.

Fig. 24 Cleaning of the pad with slide foil

## 5.1 Setting the Hand-over Position

To optimize the transfer of the labels from the printer to the pad there are two different parameters available for adjusting the hand-over position.







### Attention!

- ▶ First adjust the parameter "Hand-over position" in the printer configuration.
- ▶ Then adjust the additional hand-over position in the software.

It is very important to follow that procedure for a certain start after label loading and for the re-start after error treatment.

#### Parameter "Hand-over position" in the printer configuration

- ▶ Check the basic settings in the printer setup. Perform labelling cycles by alternately pressing the  button and Enter button .
- ▶ In the submenu  *Labelling* >  *Hand-over position* adjust the "Hand-over position" in such a way, that the blank labels are peeled-off completely from the liner

#### Hand-over Position in the software

- ▶ Check the setting in the software. Perform labelling cycles by repeatedly pressing the  button .
  - ▷ „4.2 Test Mode with a Print Job“ on page 23
- ▶ Adjust the hand-over position in such a way, that the printed labels are peeled-off completely from the liner
  - ▷ Programming manual or software documentation.

## 5.2 Activation of Peel-off Mode



### Note!

- ▶ For labelling operation activate the peel-off mode in the software.
- ▶ For direct programming use the P command ▷ Programming manual.

**Note!**

The settings in the printer configuration are basic settings for the specific printer-applicator combination. If the applicator or printer is changed, a new setting is required.

Adaptation to the respective print job must be carried out primarily via the software. Additional offset values are available here. The offset values from the device settings and the software add up during operation.

For detailed information about printer configuration ▷ [Printer configuration manual](#)

### 5.3 Settings in the Printer Menu









**Note!**

This guide only describes the specific contents of the *Labeling* menu.

More information about configuration ▷ [Printer configuration manual](#).

▶ Start menu.

▶ Select  *Setup* >  *Labeling*.

Parameter	Meaning	Default
 <i>Device info</i>	Provides device information, operational statistics and times in motion.	
 <i>Cycle sequence</i>	Setting the application mode <i>Print-Apply / Apply-Print</i> <i>Print-Apply:</i> An external start signal releases the print of a label and following the application of the label. After a cycle is complete, the pad without label waits in the start position. <i>Apply-Print:</i> An extra signal starts the print of the first label and the transfer of the label to the pad. The external start signal releases the application of the label and following the print and transfer of the next label. After a cycle is complete, the pad with a label is in the waiting position.	<i>Print-Apply</i>
 <i>Automatic FSTLBL</i>	* only with <i>Cycle sequence = Apply-print</i> The FSTLBL signal is triggered automatically in subsequence to a print job been started.	<i>Off</i>
 <i>Waiting position</i>	<i>Start position:</i> Stamp waits in starting position for the start signal <i>End position:</i> Stamp awaits start signal in end position	<i>Start position</i>
 <i>Hand-over position</i>	Shift the position of the dispensed label relative to the dispensing edge. The setting can also be adjusted by the software. The settings of configuration and software are added together.	<i>0.0 mm</i>
 <i>Support delay on</i>	Setting the switch-on delay (max. 2,5 s) for the support air between print start and switching on the support air. The delay prevents swirling at the front of the label and, consequently, avoids faults when the label is being picked up from the printer.	<i>0 ms</i>
 <i>Support delay off</i>	Setting the switch-off delay (max. 2,5 s) for the support air between the end of label forwarding and switching on the support air. The delay can be useful to separate the rear edge of the label from the carrier to avoid errors and to improve the accuracy of label positioning	<i>270 ms</i>
 <i>Start delay</i>	Delay (max. 2,5 s) between start signal and the start of an labelling cycle. Allows e.g. the use of product sensors at conveyors.	<i>0 ms</i>
 <i>Flag Initiation time</i>	Controls the time from the start of flag formation until the pliers open.	<i>250 ms</i>





Parameter	Meaning	Default
 Vacuum control	Setting the label transfer check from printer to pad and from pad to product by the vacuum sensor	On
 Flag Initiation	Creates an impulse to close the pliers and the stamp a second time.	On
 Vacuum delay	On - The vacuum will be switched on after the label feed is completed. Off - The vacuum will be switched on when the label feed starts.	Off
 START Mode	Define the condition for triggering the START signal. Edge: from low to high Level: high	Edge
 Pad empty delay	Delay after the start of the backward movement of the cylinder movement before checking whether the label has been deposited.	100 ms

Table 3 Menu Labelling

## 5.4 Special JScript Commands



### Note!

Some parameters of the menu *Setup > Labelling* can be changed or overridden by JScript commands in a print job. Numerical entries must be entered in increments of ten. These changes are valid for the current print job only.



### Attention!

The meaning of the commands  $O Ax=y$  in the following table are valid for HQ 4712 only. For other applicators the meaning of these commands are different.

#### Command $O Ax=y$

x	Meaning	Value range y	Default	Example
0	Support delay on in ms	0-2500	0	$O A0=500$
1	Support delay off in ms	0-2500	270	$O A1=500$
2	Start delay in ms	0-2500	0	$O A2=500$
3	Pliers open delay in ms	0-5000	200	$O A3=500$
4	Flag initialisation time in ms	0-2500	250	$O A4=500$
6	Transfer mode	Stamp on / Roll on / Blow on	Stamp on	$O A6=Stamp\ on$
8	Vacuum control	on / off	on	$O A8=on$
10	Flag initialisation	on / off	on	$O A10=on$
11	Vacuum delay	on / off	off	$O A11=off$
18	START Mode	Edge / Level	Edge	$O A18=Edge$
19	Pad empty delay in ms	0-1000	100	$O A19=200$

Table 4  $O Ax$  commands

### Attention!

The y-values must be set as shown in the table regarding blanks and case sensitivity.

## 6.1 Error Messages of the Printer

For detailed information about printer errors (e.g. 'Paper out', 'Ribbon out', etc.) ▷ Check the operator's manual of the printer.

Error treatment:

- ▶ Clearing the error results.
- ▶ Press the  to synchronize the label feed, remove the left over labels manually.

To quit the error state press *Repeat*.

After error correction, the label causing the error will be reprinted.

## 6.2 Error messages of the applicator

The following table contains an overview of error messages and their possible causes. It also suggests methods to resolve the problem :

Error message english	Cause	Error treatment
<i>Air Pressure to low: &lt;Value&gt; bar</i>	Pressure is too low < 4 bar	Increase pressure 4 to 6 bar
<i>Air Pressure to high: &lt;Value&gt; bar</i>	Pressure is too high > 6 bar	Reduce pressure 4 to 6 bar
<i>Label not deposited</i>	Label was not applied to product and is still on the stamp when the cylinder moves back.	Check the product position Check the lift length of the cylinder (Stopper)
<i>Not in home position after power on</i>	Stamp is outside the starting position.	Acknowledge error, applicator moves to the starting position.
<i>Home position not reached within &lt;value&gt; sec</i>	Stamp does not reach the starting position of the cylinder movement within the specified time.	Increase cylinder speed (throttle valve) Check the sensor → adjust or replace sensor
<i>Home position left unauthorized</i>	Stamp has left the starting position uncontrollably	Acknowledge error, applicator moves to the starting position.
<i>External stop</i>	Process was interrupted externally via I/O STOP.	Eliminate cause of external stop
<i>Label not taken</i>	Label was not transferred by the stamp.	Check stamp position Check vacuum
<i>Label lost during transport</i>	Label fell off the stamp before it could be applied to the product.	Stempel reinigen Vakuum überprüfen
<i>End position not reached within &lt;Value&gt; sec</i>	Stamp does not reach the end position of the cylinder movement within the specified time	Increase cylinder speed (throttle valve) Check the sensor → adjust or replace sensor
<i>Sensor information inot plausible</i>	Sensors are activated that should not be activated.	Check the sensor → adjust or replace sensor Check the applicator type in the setup
<i>Intermediate position not reached within &lt;Value&gt; sec</i>	Stamp does not reach the intermediate position of the cylinder movement within the specified time	Increase cylinder speed (throttle valve) Check the sensor → adjust or replace sensor

Table 5 Error messages of the applicator

Error treatment:

- ▶ Clear the error state.
- ▶ In order to clear the error state press **continue**, **repeat** or **cancel**.
  - Continue* with the next label in the printing queue.
  - Repeat* repeat the print of the label causing the error.
  - Only applicable with error *Vac. plate empty*.
  - Cancel* the current print job.



### Warning!

**After the error has been resolved the pad will immediately move back to the starting position!**

**Danger of injury to hands and fingers by the moving pad!**

- ▶ **Do not reach into the area of the moving pad and keep long hair, loose clothes, and jewelry away.**

Reprinting a label, interrupted by an error, is not possible without a new printing job.

- ▶ In the mode "apply/print" before the standard cyclic operation can commence the signal "print first label" must be sent or push  to send a printed label to the pad.

## 7.1 Declaration of Incorporation



cab Produkttechnik  
GmbH & Co KG  
Wilhelm-Schickard-Str. 14  
D-76131 Karlsruhe  
Germany

## EC Declaration of Incorporation

We declare herewith that the following „partly completed machinery“ as a result of design, construction and the version put in circulation complies with the essential requirements of the Directive 2006/42/EC on machinery :

Annex I, Article 1.1.2, 1.1.3, 1.1.5, 1.1.6, 1.2.1, 1.3.2, 1.5.2, 1.5.8, 1.6.3, 1.7

In the event of any alteration which has not been approved by us being made to any device as designated below, this statement shall thereby be made invalid.

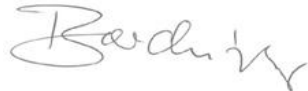
Device	<b>Flag applicator</b>
Type	<b>HQ 4712</b>
Applied EU Regulations	Applied Standards
<b>Directive 2006/42/EC on machinery</b>	<b>EN ISO 12100:2010</b>
	<b>EN ISO 13849-1:2015</b>
	<b>EN 62368-1: 2014/AC:2015</b>
Other Relevant Directives	
<ul style="list-style-type: none"> <li>• <b>Directive 2014/30/EU relating to electromagnetic compatibility</b></li> <li>• <b>Directive 2011/65/EU on the restriction of the use of certain hazardous substances in electrical and electronic equipment</b></li> </ul>	
Person authorised to compile the technical file	<b>Marcel Michalski</b> <b>Am Unterwege 18/20</b> <b>99610 Sömmerda</b>
Signed for, and on behalf of the Manufacturer	Karlsruhe, 04.02.2026
<b>cab Produkttechnik GmbH &amp; Co KG</b> <b>Wilhelm-Schickard-Str. 14</b> <b>D-76131 Karlsruhe</b>	 <b>Klaus Bardutzky</b> Managing Director

The product must not be put into service until the final machinery into which it is to be incorporated has been declared in conformity with the provisions of the Directive on machinery.

The documents according annex VII part B from the incomplete machinery are created and will commit to state agencies on request in electronic kinds.

## 7.2 EU Declaration of Conformity



cab Produkttechnik  
GmbH & Co KG  
Wilhelm-Schickard-Str. 14  
D-76131 Karlsruhe  
Germany

### EU Declaration of Conformity

We declare herewith that the following device as a result of design, construction and the version put in circulation complies with the relevant fundamental regulations of the EU Rules for Safety and Health. In the event of any alteration which has not been approved by us being made to any device as designated below, this statement shall thereby be made invalid.

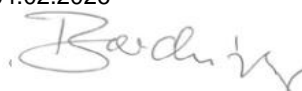
Device	<b>Flag applicator</b>
Type	<b>HQ 4712</b>
Applied EU Regulations	Applied Standards
<b>Directive 2014/30/EU relating to electromagnetic compatibility</b>	<b>EN 55032:2015+A11:2020</b>
	<b>EN 55035:2017+A11:2020</b>
	<b>EN 61000-6-2:2005/AC:2005</b>
<b>Directive 2011/65/EU on the restriction of the use of certain hazardous substances in electrical and electronic equipment</b>	<b>EN IEC 63000:2018</b>
Signed for, and on behalf of the Manufacturer	Karlsruhe, 04.02.2026
<b>cab Produkttechnik GmbH &amp; Co KG</b> <b>Wilhelm-Schickard-Str. 14</b> <b>D-76131 Karlsruhe</b>	 <b>Klaus Bardutzky</b> Managing Director