



Hub-Applikator

4114 / 4116

Familie	Typ
Hub-Applikator	4114L-200
	4114L-300
	4114L-400
	4114R-200
	4114R-300
	4114R-400
	4116L-200
	4116L-300
	4116L-400
	4116R-200
	4116R-300
	4116R-400

Inhaltsverzeichnis

1 Trägerbaugruppe 3
 2 Pneumatik Trägerbaugruppe 4
 3 Elektronik Trägerbaugruppe 5
 4 Führung 6
 5 Führung und Zylinderbaugruppe Y 7
 6 Zylinderbaugruppe Z..... 8
 7 Ersatzteilregister 9

Ausgabe: 04/2021 - Art.-Nr. 9009123

Urheberrecht

Diese Dokumentation sowie Übersetzungen hiervon sind Eigentum der cab Produkttechnik GmbH & Co KG. Das Reproduzieren, Verarbeiten, Vervielfältigen oder Verbreiten im Ganzen oder in Teilen zu anderen Zwecken als der Verfolgung seiner ursprünglichen bestimmungsgemäßen Verwendung - insbesondere die Ersatzteilbeschaffung eines von cab verkauften Gerätes - erfordert die vorherige schriftliche Genehmigung der cab.

Redaktion

Bei Fragen oder Anregungen wenden Sie sich bitte an cab Produkttechnik GmbH & Co KG Adresse „Deutschland“.

Aktualität

Durch die ständige Weiterentwicklung der Geräte können Abweichungen zwischen der Dokumentation und dem Gerät auftreten. Die aktuelle Ausgabe finden Sie unter www.cab.de.

Geschäftsbedingungen

Lieferungen und Leistungen erfolgen zu den „Allgemeinen Verkaufsbedingungen der cab“.

Deutschland
cab Produkttechnik GmbH & Co KG
 Karlsruhe
 Tel. +49 721 6626 0
www.cab.de

USA
cab Technology, Inc.
 Chelmsford, MA
 Tel. +1 978 250 8321
www.cab.de/us

Taiwan
cab Technology Co., Ltd.
 Taipeh
 Tel. +886 (02) 8227 3966
www.cab.de/tw

China
cab (Shanghai) Trading Co., Ltd.
 Guangzhou
 Tel. +86 (020) 2831 7358
www.cab.de/cn

Frankreich
cab Technologies S.à.r.l.
 Niedermodern
 Tel. +33 388 722501
www.cab.de/fr

Mexiko
cab Technology, Inc.
 Juárez
 Tel. +52 656 682 4301
www.cab.de/es

China
cab (Shanghai) Trading Co., Ltd.
 Shanghai
 Tel. +86 (021) 6236 3161
www.cab.de/cn

Südafrika
cab Technology (Pty) Ltd.
 Randburg
 Tel. +27 11 886 3580
www.cab.de/za

Nr.	Art.-Nr.	Benennung	VPE	Bem.	Serien-Nr.	
					von	bis
1	5902489.001	Schraube DIN7984-M4x8	10			
2	5964129.001	Deckel	1			
3	5965963.001	Stellschraube	1			
4	5904544.001	Druckfeder	10			
5	5964367.001	Rändelschraube	1			
6	5902241.001	Schraube DIN7984-M4x10	10			
7	5903003.001	Scheibe DIN125-A4,3	10			
8.1	5964036.001	Trägerplatte	1	L		
8.2	5964185.001	Trägerplatte	1	R		
9	5966530.001	Exzenter	1			
10.1	5966529.001	Scharnier	1	L		
10.2	5966531.001	Scharnier	1	R		
11	5964090.001	Riegel	1			
12	5903525.001	Sicherungsscheibe DIN6799-4	10			
13.1	5964429.001	Platte	1	L		
13.2	5964438.001	Platte	1	R		

Nr.	Art.-Nr.	Benennung	VPE	Bem.	Serien-Nr.	
					von	bis
14	5902021.001	Schraube DIN7991-M3x6	10			
15.1	5964318.001	Adapterprofil	1	A/B/D		
15.2	5970013.001	Adapterprofil	1	L C/D E		
15.3	5970014.001	Adapterprofil	1	R C/D E		
16	5902837.001	Schraube DIN7984-M4x8	10			
17	5902167.001	Schraube DIN912-M5x50	10			
18	5903061.001	Federring DIN127-B5	10			
19.1	5964312.001	Querträger	1	L/D		
19.2	5964331.001	Querträger	1	R/D		
19.3	5964332.001	Querträger	1	L/E		
19.4	5964333.001	Querträger	1	R/E		
20.1	5964310.001	Spannelement	1	L		
20.2	5964328.001	Spannelement	1	R		
21	5964062.001	Verbinder	1			

Bem.	L	Links
	R	Rechts
	A	200H
	B	300H
	C	400H
	D	4114
	E	4116

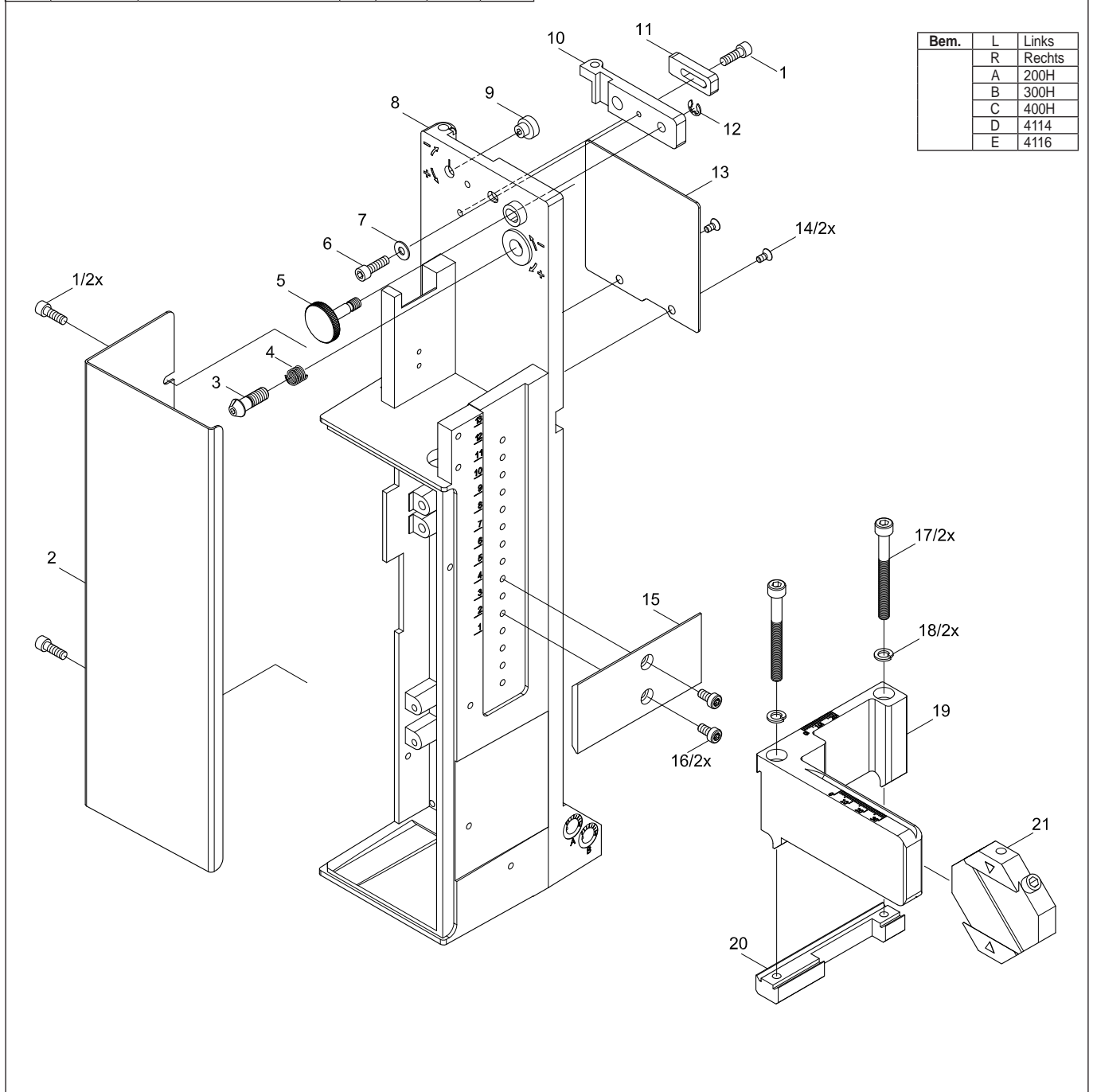

Nr.	Art.-Nr.	Benennung	VPE	Bem.	Serien-Nr.	
					von	bis
1	5902489.001	Schraube DIN7984-M4x8	10			
22	5902863.001	Schraube DIN7984-M4x25	10			
23	5905285.001	L-Steckverschraubung	1			
24	5905284.001	Absperrventil	1			
25	5966414.001	Druckminderventil	1	O		
26	5906842.001	Steckverschraubung	1			
27	5966465.001	Schlauch Ø8	2m			
28	5966460.001	Schlauch Ø4	2m			
29	5966466.001	Schlauch Ø4	2m			
30	5966464.001	Schlauch Ø6	2m			
31	5905972.001	Y-Steckverbindung	1			
32	5966463.001	Schlauch Ø4	2m			
33	5902420.001	Schraube DIN7984-M4x20	10			

Nr.	Art.-Nr.	Benennung	VPE	Bem.	Serien-Nr.	
					von	bis
34.1	5976156.001	Ventilblock	1	L		
34.2	5976157.001	Ventilblock	1	R		
35	5907428.001	Magnetventil	1			
36	5907429.001	Magnetventil	1			
37	5902862.001	Schraube DIN7984-M4x20	10			
38	5906914.001	L-Steckverschraubung	1			
39	5906844.001	Vakuumsaugdüse	1			
40	5905257.001	Schalldämpfer	1			
41	5906915.001	T-Steckverschraubung	1			
42	5905283.001	Steckverschraubung	1			
43.1	5964277.001	Blasrohr 2"	1			
43.2	5964095.001	Blasrohr 4"	1			
43.3	5964614.001	Blasrohr 6"	1			

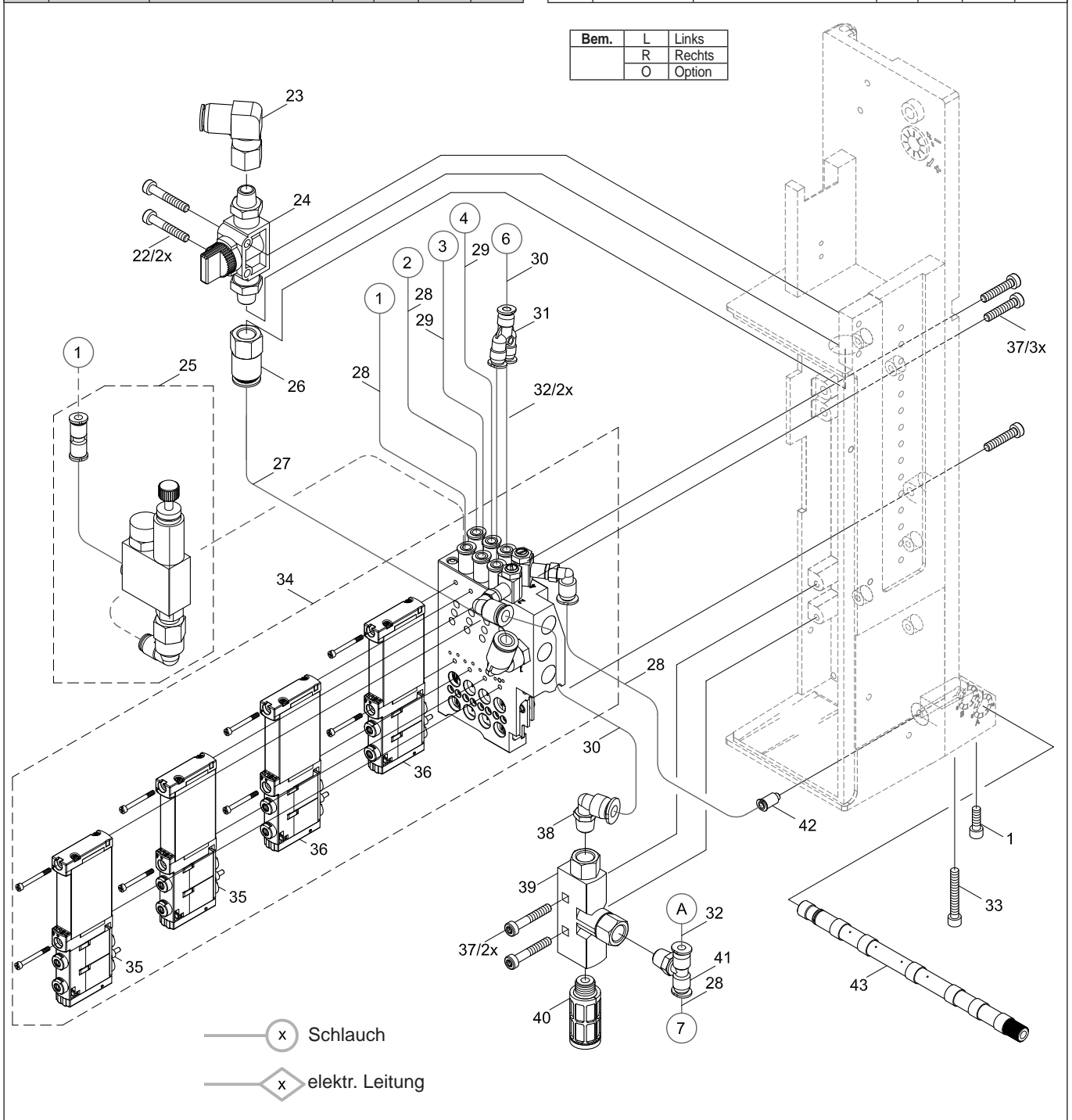

Nr.	Art.-Nr.	Benennung	VPE	Bem.	Serien-Nr.	
					von	bis
32	5966463.001	Schlauch Ø4	2m			
44	5966417.001	Halter	1			
45	5955586.001	Kabel	1			
46.1	5964590.001	Kabel	1	A		
46.2	5964591.001	Kabel	1	B		
46.3	5964592.001	Kabel	1	C		
47	5902571.001	Schraube DIN7984-M4x6	10			
48	5906943.001	Dichtring	10			
49.1	5971416.001	LP Applikatoranschlüsse	1	L		
49.2	5971417.001	LP Applikatoranschlüsse	1	R		
50.1	5964454.001	Sensor	1	A		
50.2	5964494.001	Sensor	1	B		
50.3	5964495.001	Sensor	1	C		

Nr.	Art.-Nr.	Benennung	VPE	Bem.	Serien-Nr.	
					von	bis
51.1	5964490.001	Sensor	1	A		
51.2	5964594.001	Sensor	1	B		
51.3	5964595.001	Sensor	1	C		
52.1	5971186.001	Sensor	1	A		
52.2	5971187.001	Sensor	1	B		
52.3	5971188.001	Sensor	1	C		
53.1	5971189.001	Sensor	1	A		
53.2	5971193.001	Sensor	1	B		
53.3	5971194.001	Sensor	1	C		
54	5964096.001	EEPROM	1			
55	5955575.001	LP Etikettiersteuerung	1			

Bem.	L	Links
	R	Rechts
	A	200H
	B	300H
	C	400H
	D	4114
	E	4116

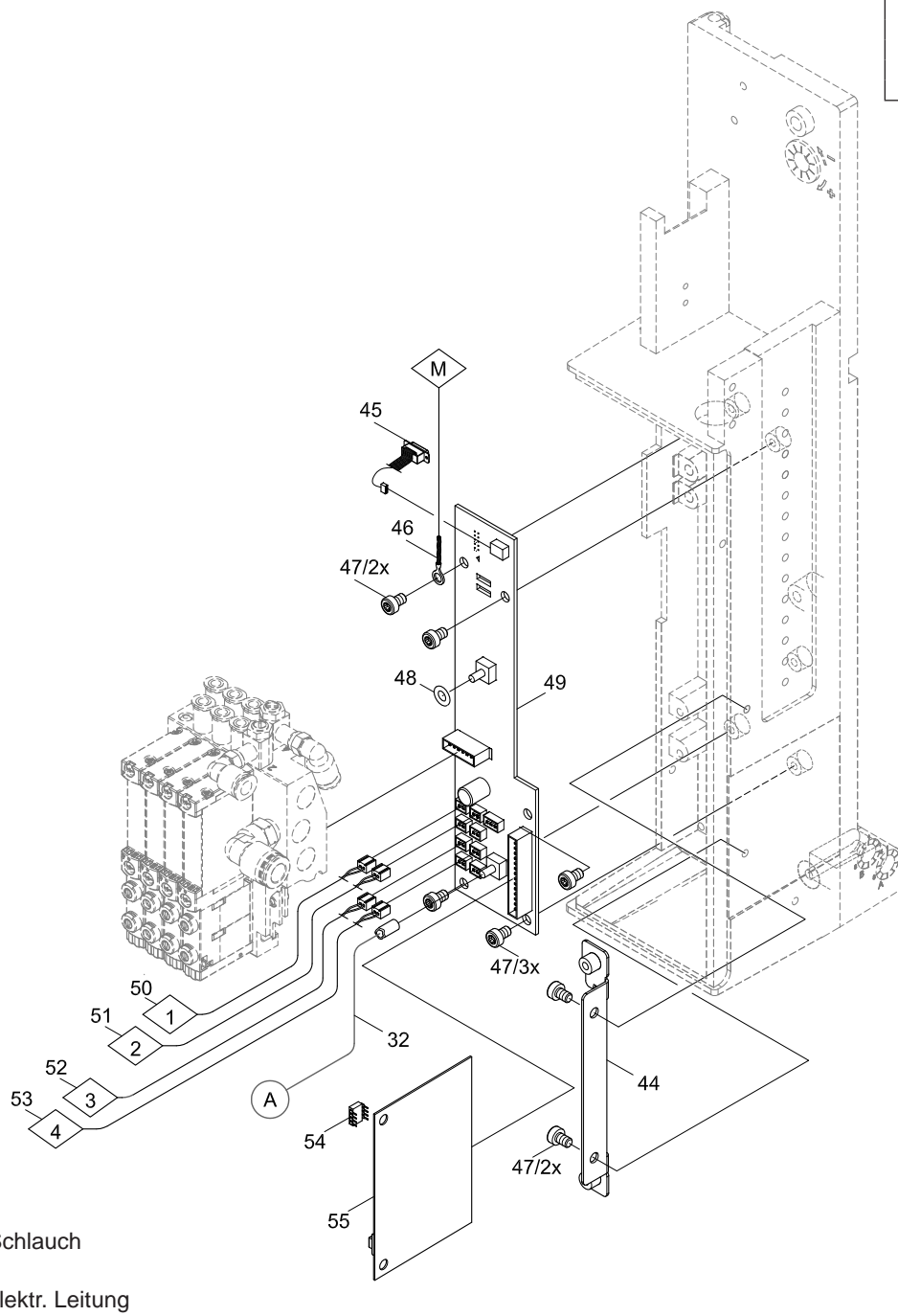

Nr.	Art.-Nr.	Benennung	VPE	Bem.	Serien-Nr.	
					von	bis
56	5521159.001	Mutter	1			
57.1	5979483.001	Anschlag	1	A/B/O		
57.2	5964343.001	Anschlag	1	C/O		
58.1	5979353.001	Anschlag	1	A/B		
58.2	5964364.001	Anschlag	1	C		
59	5964061.001	Stellschraube	1			
60.1	5979349.001	Platte	1	L/A/B		
60.2	5979417.001	Platte	1	R/A/B		
60.3	5964302.001	Platte	1	L/C		
60.4	5964337.001	Platte	1	R/C		
61	5903505.001	Sicherungsscheibe DIN6799-5	10			
62	5902827.001	Schraube DIN7984-M5x25	10	A/B		
63.1	5979331.001	Führung mit Schlitten	1	A		

Nr.	Art.-Nr.	Benennung	VPE	Bem.	Serien-Nr.	
					von	bis
63.2	5979342.001	Führung mit Schlitten	1	B		
64.1	5964301.001	Halter	1	L		
64.2	5964336.001	Halter	1	R		
65	5902562.001	Schraube DIN7984-M4x14	10			
66	5903040.001	Scheibe DIN125-A6,4	10			
67	5902504.001	Mutter DIN934-M6	10			
68	5964349.001	Anschlag	1			
69	5979307.001	Führungsschiene	1	C		
70.1	5966524.001	Stütze	1	L/C		
70.2	5966528.001	Stütze	1	R/C		
71	5902291.001	Schraube DIN7991-M4x20	10			
72	5965966.001	Schlitten	1	C		
73	5902375.001	Schraube DIN7984-M6x10	10	C		

Bem.	L	Links
	R	Rechts
	A	200H
	B	300H
	C	400H
	D	4114
	E	4116
	O	Option

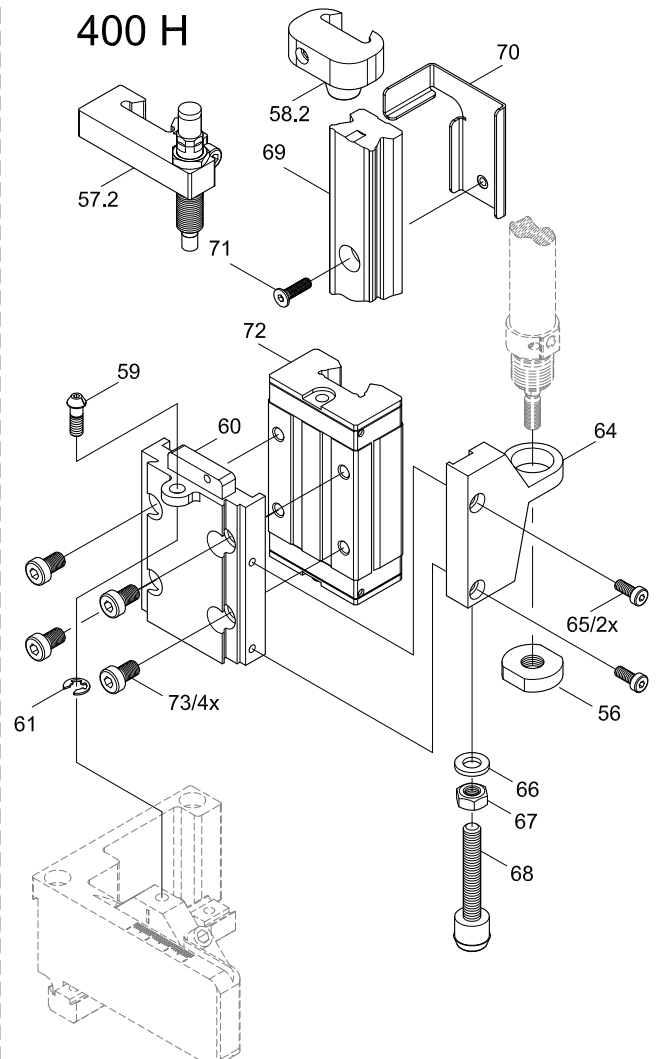
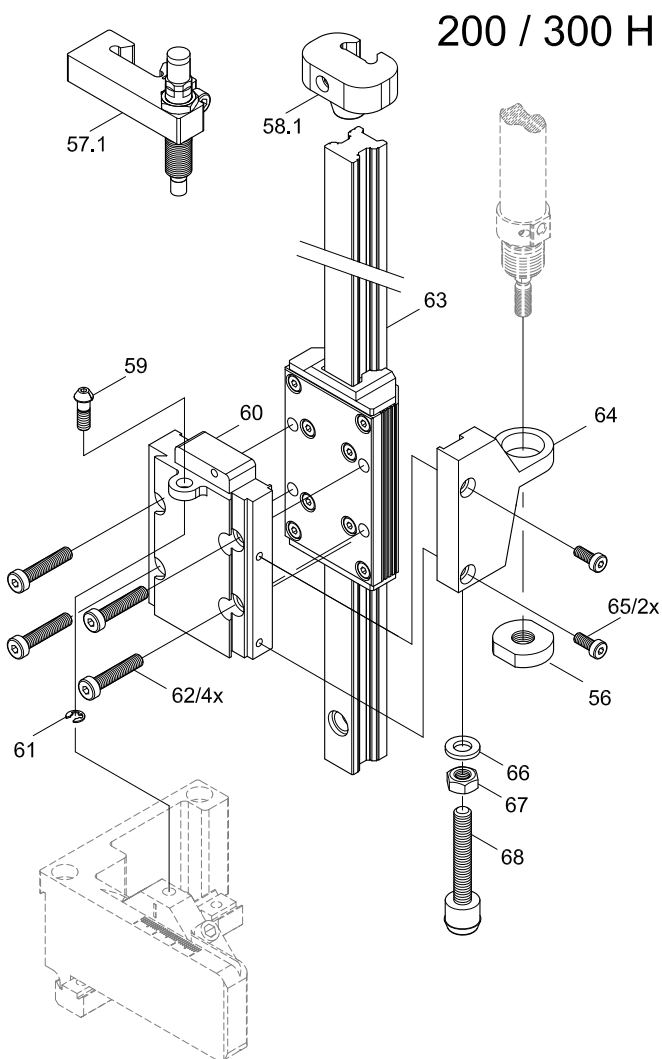

— (x) Schlauch

— (x) elektr. Leitung

Nr.	Art.-Nr.	Benennung	VPE	Bem.	Serien-Nr.	
					von	bis
29	5966466.001	Schlauch Ø4	2m			
51.1	5964490.001	Sensor	1	A		
51.2	5964594.001	Sensor	1	B		
51.3	5964595.001	Sensor	1	C		
52.1	5971186.001	Sensor	1	A		
52.2	5971187.001	Sensor	1	B		
52.3	5971188.001	Sensor	1	C		
53.1	5971189.001	Sensor	1	A		
53.2	5971193.001	Sensor	1	B		
53.3	5971194.001	Sensor	1	C		
74	5979327.001	Adapter Schiene	1			
75.1	5964236.001	Stempelaufnahme	1	L		
75.2	5964241.001	Stempelaufnahme	1	R		
76.1	5964246.001	Platte	1	L/D		
76.2	5964247.001	Platte	1	R/D		
76.3	5971163.001	Platte	1	E		

Nr.	Art.-Nr.	Benennung	VPE	Bem.	Serien-Nr.	
					von	bis
77	5955707.001	Adapterbolzen	1			
78.1	5905069.001	Druckfeder	1	M1		
78.2	5905049.001	Druckfeder	1	M2		
79	5521157.001	Scheibe	1			
80	5521158.001	Scheibe	1			
81	5903501.001	Sicherungsscheibe DIN6799-7	10			
82	5902138.001	Schraube DIN912-M5x10	10			
83	5906690.001	Mini-Schlitten	1			
84	5906636.001	Drossel-Rückschlagventil	1			
85.1	5964456.001	Adapter	1	D		
85.2	5974610.001	Adapter	1	E		
86	5902018.001	Schraube DIN912-M3x16	10			
87	5905371.001	Y-Steckverbindung	1	E		
88	5905255.001	L-Steckverschraubung	1			
89	5902838.001	Schraube DIN7984-M3x6	10			

Bem.	L	Links
	R	Rechts
	A	200H
	B	300H
	C	400H
	D	4114
	E	4116
	O	Option
	M1	Appl. nach unten / horizontal
	M2	Appl. nach oben

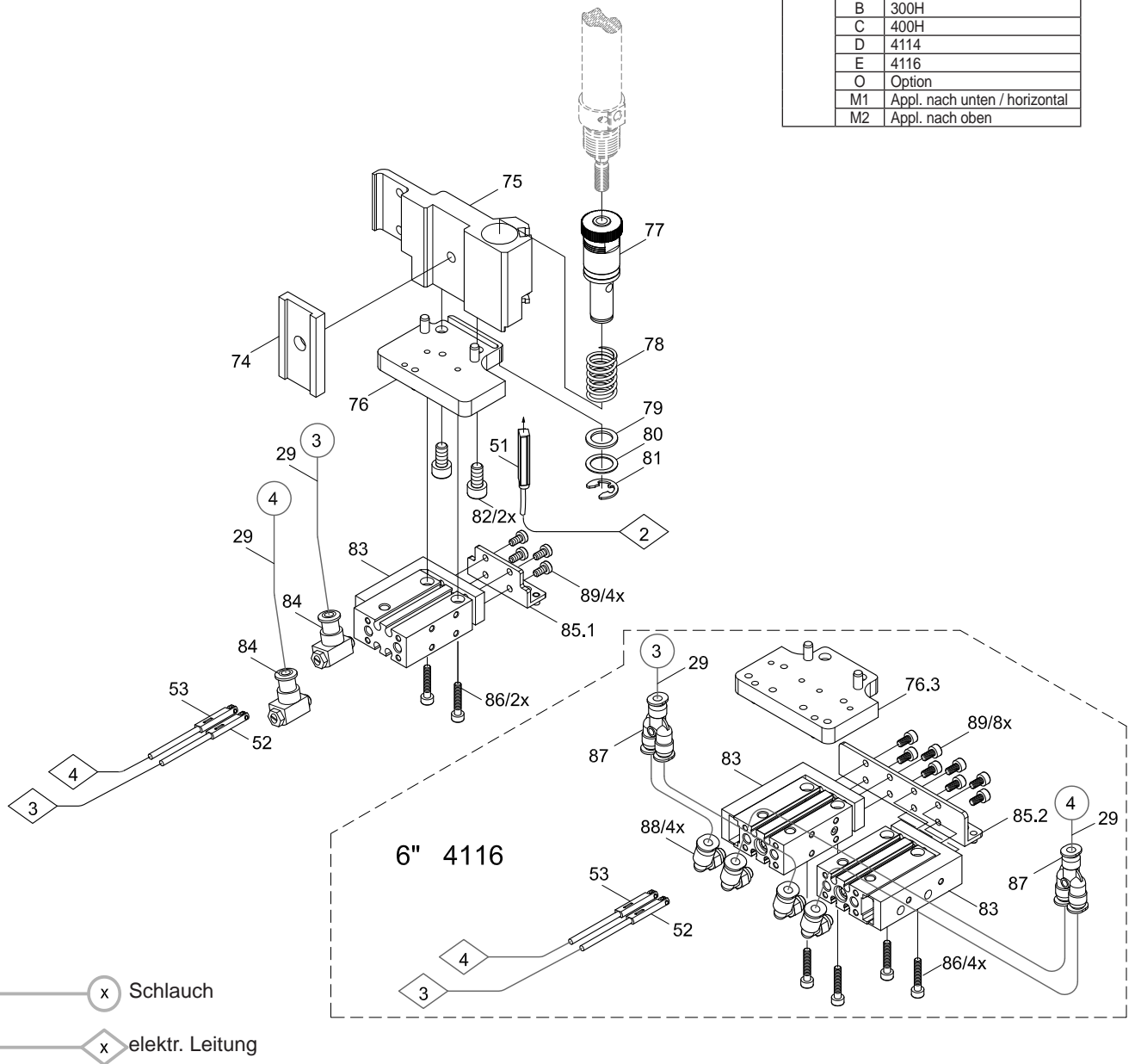

Nr.	Art.-Nr.	Benennung	VPE	Bem.	Serien-Nr.	
					von	bis
1	5902489.001	Schraube DIN7984-M4x8	10			
28	5966460.001	Schlauch Ø4	2m			
30	5966464.001	Schlauch Ø6	2m			
46.1	5964590.001	Kabel	1	A		
46.2	5964591.001	Kabel	1	B		
46.3	5964592.001	Kabel	1	C		
50.1	5964454.001	Sensor	1	A		
50.2	5964494.001	Sensor	1	B		
50.3	5964495.001	Sensor	1	C		
84	5906636.001	Drossel-Rückschlagventil	1			
90	5902047.001	Schraube DIN7991-M3x5	10			
91.1	5964347.001	Winkel	1	L/A		
91.2	5964396.001	Winkel	1	R/A		
91.3	5964357.001	Winkel	1	L/B		
91.4	5964398.001	Winkel	1	R/B		
91.5	5964358.001	Winkel	1	L/C		
91.6	5964402.001	Winkel	1	R/C		
92	5964443.001	Bolzen	1	A		

Nr.	Art.-Nr.	Benennung	VPE	Bem.	Serien-Nr.	
					von	bis
93	5964489.001	Rändelmutter	1	B/C		
94	5905593.001	Befestigungsschelle	1			
95.1	5906938.001	Zylinder	1	A		
95.2	5905973.001	Zylinder	1	B		
95.3	5906117.001	Zylinder	1	C		
96.1	5964440.001	Abdeckung	1	L/A		
96.2	5964451.001	Abdeckung	1	R/A		
96.3	5964483.001	Abdeckung	1	L/B		
96.4	5964453.001	Abdeckung	1	R/B		
96.5	5964484.001	Abdeckung	1	L/C		
96.6	5964485.001	Abdeckung	1	R/C		
97.1	5902895.001	Schraube DIN7984-M 6x30	10	A/B		
97.2	5909043.001	Schraube DIN7984-M6x20	10	C		
98.1	5964373.001	Energiekette	1	A		
98.2	5964374.001	Energiekette	1	B		
98.3	5964375.001	Energiekette	1	C		
99		Stempel				

Bem.	L	Links
R		Rechts
A		200H
B		300H
C		400H
D		4114
E		4116

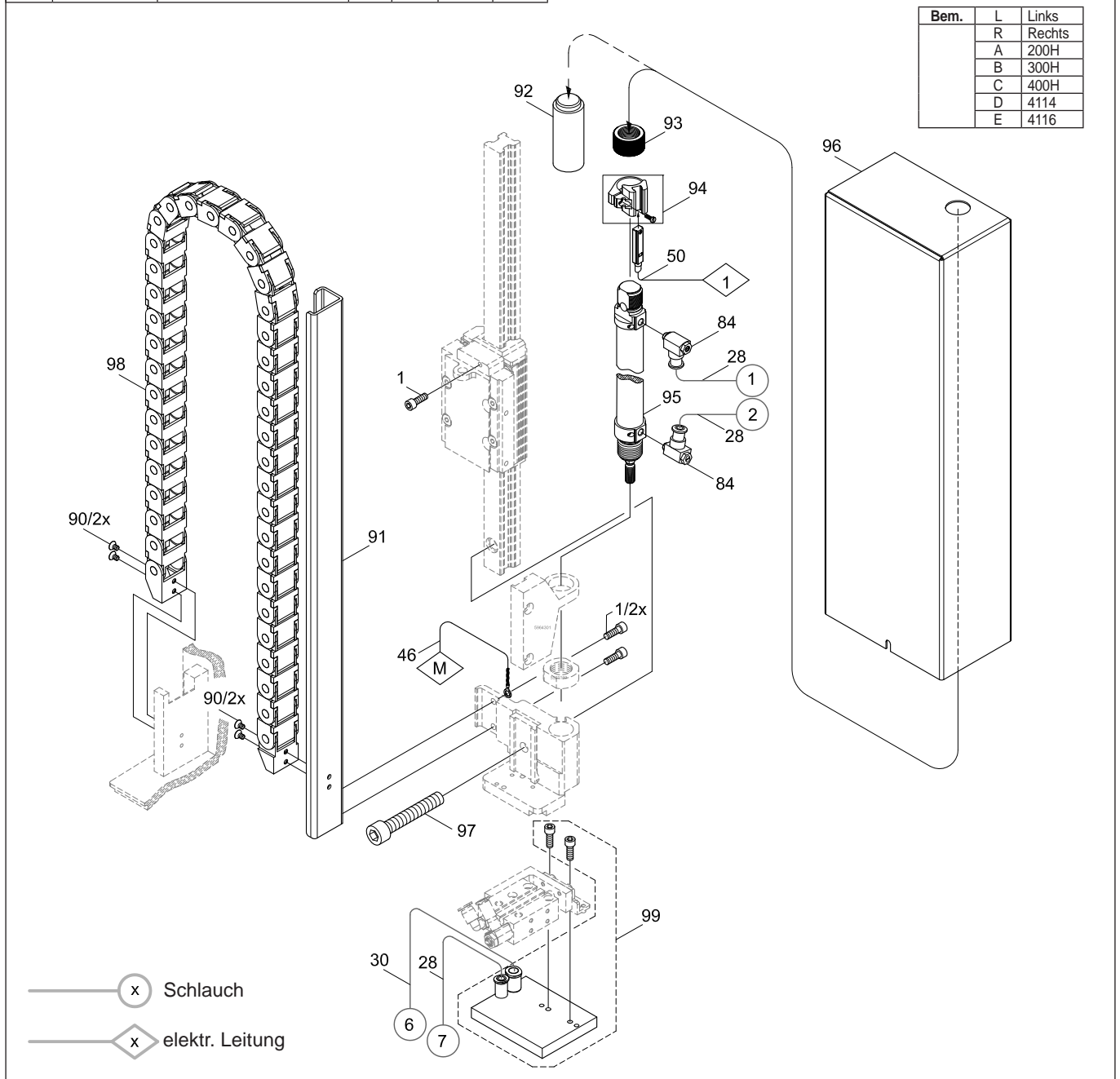

lfd.Nr.	Abbildung/Seite				Nr.	Artikel-Nr.	Bezeichnung	VPE	EE				Bemerkung	Serien-Nr.	
									von	bis					
1				7	79	5521157.001	Scheibe	1	-	-	-	-			
2				7	80	5521158.001	Scheibe	1	-	-	-	-			
3			6		56	5521159.001	Mutter	1	-	-	-	-			
4				7	86	5902018.001	Schraube DIN912-M3x16	10	-	-	-	-			
5	3				14	5902021.001	Schraube DIN7991-M3x6	10	-	-	-	-			
6				8	90	5902047.001	Schraube DIN7991-M3x5	10	-	-	-	-			
7				7	82	5902138.001	Schraube DIN912-M5x10	10	-	-	-	-			
8	3				17	5902167.001	Schraube DIN912-M5x50	10	-	-	-	-			
9	3				6	5902241.001	Schraube DIN7984-M4x10	10	-	-	-	-			
10			6		71	5902291.001	Schraube DIN7991-M4x20	10	-	-	-	-			
11			6		73	5902375.001	Schraube DIN7984-M6x10	10	-	-	-	-	C		
12		4			33	5902420.001	Schraube DIN7984-M4x20	10	-	-	-	-			
13	3	4		8	1	5902489.001	Schraube DIN7984-M4x8	10	-	-	-	-			
14			6		67	5902504.001	Mutter DIN934-M6	10	-	-	-	-			
15			6		65	5902562.001	Schraube DIN7984-M4x14	10	-	-	-	-			
16			5		47	5902571.001	Schraube DIN7984-M4x6	10	-	-	-	-			
17			6		62	5902827.001	Schraube DIN7984-M5x25	10	-	-	-	-	A/B		
18	3				16	5902837.001	Schraube DIN7984-M4x8	10	-	-	-	-			
19				7	89	5902838.001	Schraube DIN7984-M3x6	10	-	-	-	-			
20		4			37	5902862.001	Schraube DIN7984-M4x20	10	-	-	-	-			
21		4			22	5902863.001	Schraube DIN7984-M4x25	10	-	-	-	-			
22				8	97.1	5902895.001	Schraube DIN7984-M 6x30	10	-	-	-	-	A/B		
23	3				7	5903003.001	Scheibe DIN125-A4,3	10	-	-	-	-			
24			6		66	5903040.001	Scheibe DIN125-A6,4	10	-	-	-	-			
25	3				18	5903061.001	Federring DIN127-B5	10	-	-	-	-			
26				7	81	5903501.001	Sicherungsscheibe DIN6799-7	10	-	-	-	-			
27			6		61	5903505.001	Sicherungsscheibe DIN6799-5	10	-	-	-	-			
28	3				12	5903525.001	Sicherungsscheibe DIN6799-4	10	-	-	-	-			
29	3				4	5904544.001	Druckfeder	10	-	-	-	-			
30				7	78.2	5905049.001	Druckfeder	1	-	-	C	D	M2		
31				7	78.1	5905069.001	Druckfeder	1	-	-	C	D	M1		
32				7	88	5905255.001	L-Steckverschraubung	1	-	-	-	-			
33		4			40	5905257.001	Schalldämpfer	1	A	B	C	D			
34		4			42	5905283.001	Steckverschraubung	1	-	-	-	-			
35		4			24	5905284.001	Absperrventil	1	-	-	-	-			
36		4			23	5905285.001	L-Steckverschraubung	1	-	-	-	-			
37				7	87	5905371.001	Y-Steckverbindung	1	-	-	-	-	E		
38				8	94	5905593.001	Befestigungsschelle	1	-	-	-	-			
39		4			31	5905972.001	Y-Steckverbindung	1	-	-	-	-			
40				8	95.2	5905973.001	Zylinder	1	-	-	C	D	B		
41				8	95.3	5906117.001	Zylinder	1	-	-	C	D	C		
42				7	8	84	5906636.001	Drossel-Rückschlagventil	1	A	B	C	D		
43				7	83	5906690.001	Mini-Schlitten	1	-	-	-	-			
44		4			26	5906842.001	Steckverschraubung	1	-	-	-	-			
45		4			39	5906844.001	Vakuumsaugdüse	1	-	-	-	-			
46		4			38	5906914.001	L-Steckverschraubung	1	-	-	-	-			
47		4			41	5906915.001	T-Steckverschraubung	1	-	-	-	-			
48				8	95.1	5906938.001	Zylinder	1	-	-	C	D	A		
49			5		48	5906943.001	Dichtring	10	-	-	-	-			
50		4			35	5907428.001	Magnetventil	1	-	B	C	D			
51		4			36	5907429.001	Magnetventil	1	-	B	C	D			
52				8	97.2	5909043.001	Schraube DIN7984-M6x20	10	-	-	-	-	C		
53			5		55	5955575.001	LP Etikettiersteuerung	1	-	-	C	D			
54			5		45	5955586.001	Kabel	1	-	-	C	D			
55				7	77	5955707.001	Adapterbolzen	1	-	-	-	-			
56	3				8.1	5964036.001	Trägerplatte	1	-	-	-	-	L		

VPE Verpackungseinheit

Bemerkungen

L Links
R Rechts
A 200
B 300
C 400
D 4114
E 4116

M1 Appl. nach unten / horizontal
M2 Appl. nach oben
O Option

EE Ersatzteil - Empfehlung

A - Verschleißteile und Zubehör
B - empfohlene Baugruppen für schnelle Reparatur
C - empfohlene Ersatzteile für Händler
D - empfohlene Ersatzteile für Zentrallager

Ifd.Nr.	Abbildung/Seite				Nr.	Artikel-Nr.	Bezeichnung	VPE	EE				Bemerkung	Serien-Nr.	
														von	bis
57			6		59	5964061.001	Stellschraube	1	-	-	-	-			
58	3				21	5964062.001	Verbinder	1	-	-	-	-			
59	3				11	5964090.001	Riegel	1	-	-	-	-			
60		4			43.2	5964095.001	Blasrohr 4"	1	-	-	-	-			
61			5		54	5964096.001	EEPROM	1	-	-	-	-			
62	3				2	5964129.001	Deckel	1	-	-	-	-			
63	3				8.2	5964185.001	Trägerplatte	1	-	-	-	-	R		
64				7	75.1	5964236.001	Stempelaufnahme	1	-	-	-	-	L		
65				7	75.2	5964241.001	Stempelaufnahme	1	-	-	-	-	R		
66				7	76.1	5964246.001	Platte	1	-	-	-	-	L/D		
67				7	76.2	5964247.001	Platte	1	-	-	-	-	R/D		
68		4			43.1	5964277.001	Blasrohr 2"	1	-	-	-	-			
69			6		64.1	5964301.001	Halter	1	-	-	-	-	L		
70			6		60.3	5964302.001	Platte	1	-	-	-	-	L/C		
71	3				20.1	5964310.001	Spannelement	1	-	-	-	-	L		
72	3				19.1	5964312.001	Querträger	1	-	-	-	-	L/D		
73	3				15.1	5964318.001	Adapterprofil	1	-	-	-	-	A/B/D		
74	3				20.2	5964328.001	Spannelement	1	-	-	-	-	R		
75	3				19.2	5964331.001	Querträger	1	-	-	-	-	R/D		
76	3				19.3	5964332.001	Querträger	1	-	-	-	-	L/E		
77	3				19.4	5964333.001	Querträger	1	-	-	-	-	R/E		
78			6		64.2	5964336.001	Halter	1	-	-	-	-	R		
79			6		60.4	5964337.001	Platte	1	-	-	-	-	R/C		
80			6		57.2	5964343.001	Anschlag	1	-	-	-	-	C/O		
81				8	91.1	5964347.001	Winkel	1	-	-	-	-	L/A		
82			6		68	5964349.001	Anschlag	1	-	-	-	-			
83				8	91.3	5964357.001	Winkel	1	-	-	-	-	L/B		
84				8	91.5	5964358.001	Winkel	1	-	-	-	-	L/C		
85			6		58.2	5964364.001	Anschlag	1	-	-	-	-	C		
86	3				5	5964367.001	Rändelschraube	1	-	-	-	-			
87				8	98.1	5964373.001	Energiekette	1	-	-	-	-	A		
88				8	98.2	5964374.001	Energiekette	1	-	-	-	-	B		
89				8	98.3	5964375.001	Energiekette	1	-	-	-	-	C		
90				8	91.2	5964396.001	Winkel	1	-	-	-	-	R/A		
91				8	91.4	5964398.001	Winkel	1	-	-	-	-	R/B		
92				8	91.6	5964402.001	Winkel	1	-	-	-	-	R/C		
93	3				13.1	5964429.001	Platte	1	-	-	-	-	L		
94	3				13.2	5964438.001	Platte	1	-	-	-	-	R		
95				8	96.1	5964440.001	Abdeckung	1	-	-	-	-	L/A		
96				8	92	5964443.001	Bolzen	1	-	-	-	-	A		
97				8	96.2	5964451.001	Abdeckung	1	-	-	-	-	R/A		
98				8	96.4	5964453.001	Abdeckung	1	-	-	-	-	R/B		
99		5		8	50.1	5964454.001	Sensor	1	-	-	-	-	A		
100				7	85.1	5964456.001	Adapter	1	-	-	-	-	D		
101				8	96.3	5964483.001	Abdeckung	1	-	-	-	-	L/B		
102				8	96.5	5964484.001	Abdeckung	1	-	-	-	-	L/C		
103				8	96.6	5964485.001	Abdeckung	1	-	-	-	-	R/C		
104				8	93	5964489.001	Rändelmutter	1	-	-	-	-	B/C		
105		5		7	51.1	5964490.001	Sensor	1	-	-	C	D	A		
106		5		8	50.2	5964494.001	Sensor	1	-	-	C	D	B		
107		5		8	50.3	5964495.001	Sensor	1	-	-	C	D	C		
108		5		8	46.1	5964590.001	Kabel	1	-	-	C	D	A		
109		5		8	46.2	5964591.001	Kabel	1	-	-	C	D	B		
110		5		8	46.3	5964592.001	Kabel	1	-	-	C	D	C		
111		5		7	51.2	5964594.001	Sensor	1	-	-	C	D	B		
112		5		7	51.3	5964595.001	Sensor	1	-	-	C	D	C		

VPE Verpackungseinheit

Bemerkungen

L Links
R Rechts
A 200
B 300
C 400
D 4114
E 4116

M1 Appl. nach unten / horizontal
M2 Appl. nach oben
O Option

EE Ersatzteil - Empfehlung

A - Verschleißteile und Zubehör
B - empfohlene Baugruppen für schnelle Reparatur
C - empfohlene Ersatzteile für Händler
D - empfohlene Ersatzteile für Zentrallager

lfd.Nr.	Abbildung/Seite					Nr.	Artikel-Nr.	Bezeichnung	VPE	EE				Bemerkung	Serien-Nr.	
																von
113		4				43.3	5964614.001	Blasrohr 6"	1	-	-	-	-			
114	3					3	5965963.001	Stellschraube	1	-	-	-	-			
115			6			72	5965966.001	Schlitten	1	-	-	-	-	C		
116		4				25	5966414.001	Druckminderventil	1	-	-	-	-	O		
117			5			44	5966417.001	Halter	1	-	-	-	-			
118		4			8	28	5966460.001	Schlauch Ø4	2m	-	B	C	D			
119		4	5			32	5966463.001	Schlauch Ø4	2m	-	B	C	D			
120		4			8	30	5966464.001	Schlauch Ø6	2m	-	B	C	D			
121		4				27	5966465.001	Schlauch Ø8	2m	-	B	C	D			
122		4			7	29	5966466.001	Schlauch Ø4	2m	-	B	C	D			
123				6		70.1	5966524.001	Stütze	1	-	-	-	-	L/C		
124				6		70.2	5966528.001	Stütze	1	-	-	-	-	R/C		
125	3					10.1	5966529.001	Scharnier	1	-	-	-	-	L		
126	3					9	5966530.001	Exzenter	1	-	-	-	-			
127	3					10.2	5966531.001	Scharnier	1	-	-	-	-	R		
128	3					15.2	5970013.001	Adapterprofil	1	-	-	-	-	L C/D E		
129	3					15.3	5970014.001	Adapterprofil	1	-	-	-	-	R C/D E		
130					7	76.3	5971163.001	Platte	1	-	-	-	-	E		
131			5		7	52.1	5971186.001	Sensor	1	-	-	C	D	A		
132			5		7	52.2	5971187.001	Sensor	1	-	-	C	D	B		
133			5		7	52.3	5971188.001	Sensor	1	-	-	C	D	C		
134			5		7	53.1	5971189.001	Sensor	1	-	-	C	D	A		
135			5		7	53.2	5971193.001	Sensor	1	-	-	C	D	B		
136			5		7	53.3	5971194.001	Sensor	1	-	-	C	D	C		
137			5			49.1	5971416.001	LP Applikatoranschlüsse	1	-	B	C	D	L		
138			5			49.2	5971417.001	LP Applikatoranschlüsse	1	-	B	C	D	R		
139					7	85.2	5974610.001	Adapter	1	-	-	-	-	E		
140		4				34.1	5976156.001	Ventilblock	1	-	-	-	-	L		
141		4				34.2	5976157.001	Ventilblock	1	-	-	-	-	R		
142				6		69	5979307.001	Führungsschiene	1	-	-	-	-	C		
143					7	74	5979327.001	Adapter Schiene	1	-	-	-	-			
144				6		63.1	5979331.001	Führung mit Schlitten	1	-	-	-	-	A		
145				6		63.2	5979342.001	Führung mit Schlitten	1	-	-	-	-	B		
146				6		60.1	5979349.001	Platte	1	-	-	-	-	L/A/B		
147				6		58.1	5979353.001	Anschlag	1	-	-	-	-	A/B		
148				6		60.2	5979417.001	Platte	1	-	-	-	-	R/A/B		
149				6		57.1	5979483.001	Anschlag	1	-	-	-	-	A/B/O		
150							9109134.001	Verpackung	1	-	-	-	-			

VPE Verpackungseinheit

EE Ersatzteil - Empfehlung

A - Verschleißteile und Zubehör

B - empfohlene Baugruppen für schnelle Reparatur

C - empfohlene Ersatzteile für Händler

D - empfohlene Ersatzteile für Zentrallager

Bemerkungen

L Links

R Rechts

A 200

B 300

C 400

D 4114

E 4116

M1 Appl. nach unten / horizontal

M2 Appl. nach oben

O Option