

Assembly Instructions

Air Pressure Regulation Unit HERMES Q

Edition: 11/2020 · Part No. 9003648

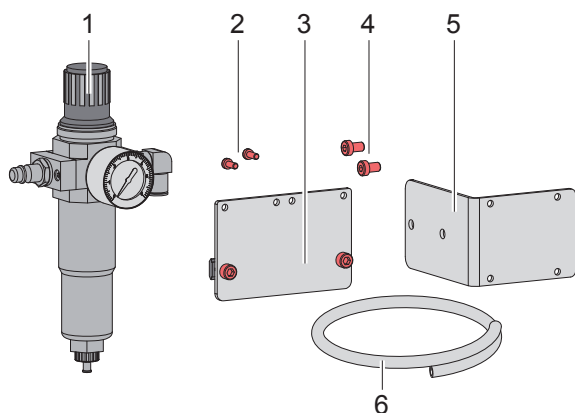

Versions

- | | |
|---------|---|
| 6010880 | Air Pressure Regulation Unit L
for HERMES QL |
| 6010881 | Air Pressure Regulation Unit R
for HERMES QR |

Contents of Delivery

- 1 - Air Pressure Regulation Unit
- 2 - 2 Screws M4x10
- 3 - Connector
- 4 - 2 Screws M6x10
- 5 - Bracket
- 6 - Tube

Mounting

Attaching to the Bracket

- ▶ Attach the air pressure regulation unit (1) with 2 screws M4x10 (2) to the connector (3).
- ▶ Insert the slot nuts (7) of the mounted unit into the slot (10) of the bracket (9).
- ▶ Tighten the screws (8).

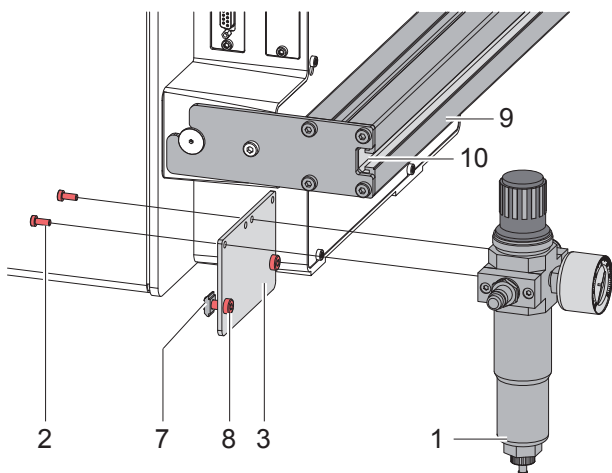

Attaching to the Chassis of the Printer

- ▶ Attach the air pressure regulation unit (1) with 2 screws M4x10 (2) to the bracket (5).
- ▶ Attach the mounted unit with 2 screws M6x10 (4) to the drillings (11) of the chassis.

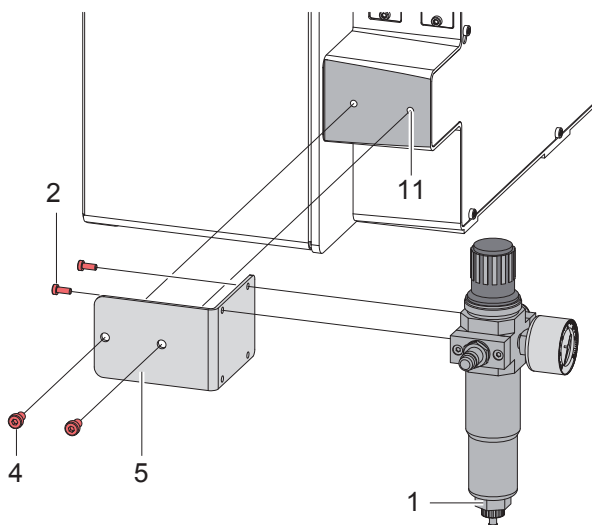

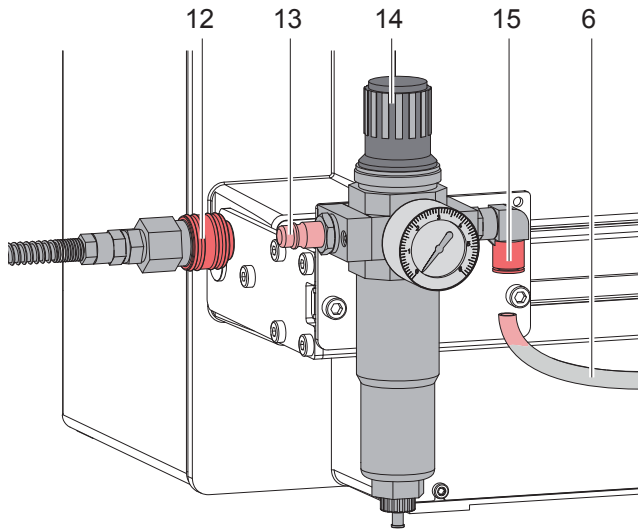

Compressed Air Connection

- ▶ Insert the tube (6) into the connector (15) of the air pressure regulation unit.
- ▶ Connect the tube (6) to the applicator.
- ▶ Connect the compressed air supply (12) to the plug (13). The plug is suitable for a coupling connector DN 7.2.
- ▶ Lift the cap (14).
- ▶ Set the operating pressure of **4.5 bar**.
- ▶ Press down the cap (14).

Detailed information on the air pressure regulation unit:

https://www.festo.com/net/SupportPortal/Files/538243/LFR-D_2018-08j_8093026g1.pdf

Germany
cab Produkttechnik GmbH & Co KG
 Karlsruhe
 Phone +49 721 6626 0
www.cab.de

USA
cab Technology, Inc.
 Chelmsford, MA
 Phone +1 978 250 8321
www.cab.de/us

Taiwan
cab Technology Co., Ltd.
 Taipei
 Phone +886 (02) 8227 3966
www.cab.de/tw

China
cab (Shanghai) Trading Co., Ltd.
 Guangzhou
 Phone +86 (020) 2831 7358
www.cab.de/cn

France
cab Technologies S.à.r.l.
 Niedermodern
 Phone +33 388 722501
www.cab.de/fr

Mexico
cab Technology, Inc.
 Juárez
 Phone +52 656 682 4301
www.cab.de/es

China
cab (Shanghai) Trading Co., Ltd.
 Shanghai
 Phone +86 (021) 6236 3161
www.cab.de/cn

South Africa
cab Technology (Pty) Ltd.
 Randburg
 Phone +27 11 886 3580
www.cab.de/za