

Interface Description



Label Printer

Hermes+ / Hermes C

Made in Germany

2 Interface Description - Translation of the Original Version for the following products

2

Family	Type
Hermes+ L	Hermes+ 2L
	Hermes+ 4L
	Hermes+ 4.3L
	Hermes+ 6L
Hermes+ R	Hermes+ 2R
	Hermes+ 4R
	Hermes+ 4.3R
	Hermes+ 6R
Hermes C	Hermes C6

Edition: 07/2016 - Part No. 9009797

Copyright

This documentation as well as translation hereof are property of cab Produkttechnik GmbH & Co. KG.

The replication, conversion, duplication or divulgement of the whole manual or parts of it for other intentions than its original intended purpose demand the previous written authorization by cab.

Trademark

Microsoft® is a registered trademark of the Microsoft Corporation.

Windows® is a registered trademark of the Microsoft Corporation.

Editor

Regarding questions or comments please contact cab Produkttechnik GmbH & Co. KG.

Topicality

Due to the constant further development of our products discrepancies between documentation and product can occur.

Please check www.cab.de for the latest update.

Terms and conditions

Deliveries and performances are effected under the General conditions of sale of cab.

Germany

cab Produkttechnik
GmbH & Co KG
Postfach 1904
D-76007 Karlsruhe
Wilhelm-Schickard-Str. 14
D-76131 Karlsruhe

Telefon +49 721 6626-0
Telefax +49 721 6626-249

www.cab.de
info@cab.de

France

cab technologies s.a.r.l.
F-67350 Niedermodern
Téléphone +33 388 722 501
www.cab.de/fr
info.fr@cab.de

USA

cab Technology Inc.
Tyngsboro MA, 01879
Phone +1 978 649 0293
www.cab.de/us
info.us@cab.de

Asia 亚洲

cab Technology Co., Ltd.
希愛比科技股份有限公司
Junghe, Taipei, Taiwan
Phone +886 2 8227 3966
www.cab.de/tw
info.asia@cab.de

China 中国

cab (Shanghai) Trading Co., Ltd.
乾博(上海)贸易有限公司
Phone +86 21 6236-3161
www.cab.de/cn
info.cn@cab.de

Representatives in other countries on request

1	Introduction	4
1.1	Instructions	4
1.2	Content of the Documentation	5
2	I/O Interface	6
2.1	Pin Assignment	6
2.2	Circuit Diagram of Inputs and Outputs	8
2.3	External Minimum Circuit	9
2.4	Signal Map	10
2.5	I/O Interface Adapter Hermes A - Hermes+	11
3	Connector Warning Light	12
4	Connector Emergency Stop	12
5	Connector Central Compressed Air Valve	12

1.1 Instructions

Important information and instructions are designated as follows:

**Danger!**

Draws attention to an exceptionally great, imminent danger to your health or life due to hazardous voltages.

**Danger!**

Draws attention to a danger with high risk which, if not avoided, may result in death or serious injury.

**Warning!**

Draws attention to a danger with medium risk which, if not avoided, may result in death or serious injury.

**Caution!**

Draws attention to a danger with low risk which, if not avoided, may result in minor or moderate injury.

**Attention!**

Draws attention to potential risks of property damage or loss of quality.

**Note!**

Advices to make work routine easier or on important steps to be carried out.

**Environment!**

Advices on protecting the environment.

- ▶ Handling instructions
- ▷ Reference to chapter, position, picture number or document.
- * Option (accessories, peripherals, extras).

Time Viewed in the display / monitor.

1.2 Content of the Documentation

The documentation contains the description of the following interfaces, which are especially defined for Hermes C :

- I/O interface (10)
- Connector warning light (11)
- Connector emergency stop (12)
- Connector central compressed air valve (9)

The RS-232 interface (11) is uniformly defined for all cab label printers ▷ Configuration Manual.

The interface for cab Applicators is an USB interface for data transfer between cab modules only. Therefore there is no further description in this manual.

All other interfaces are standardized and therefore no matter of this documentation.

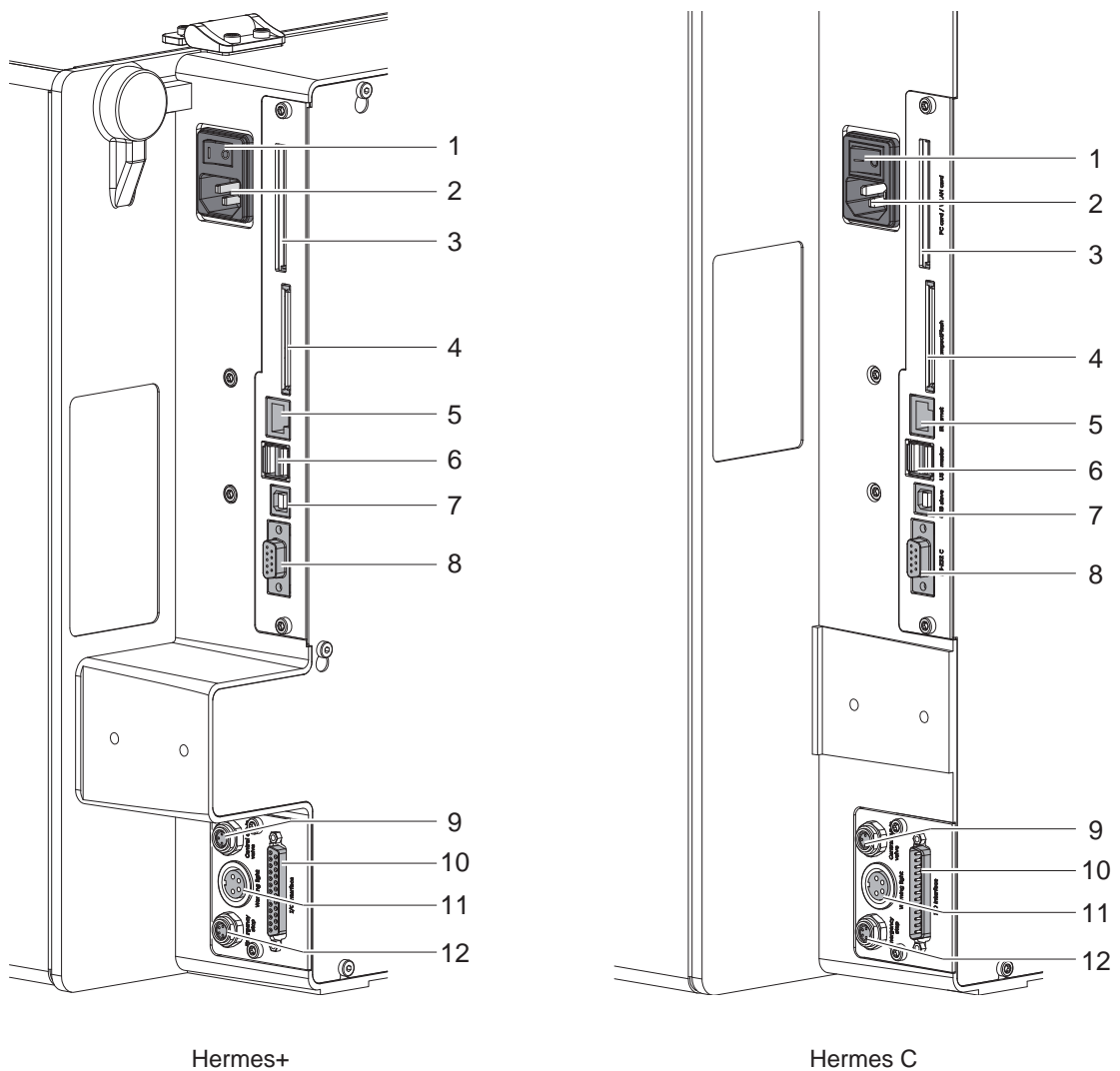

- 1 Power switch
- 2 Power connection jack
- 3 Slot for PC Card Type II or WLAN card
- 4 Slot for CompactFlash memory card
- 5 Ethernet 10/100 Base-T
- 6 2 USB master ports for keyboard, scanner or service key

- 7 USB high-speed slave port
- 8 Serial RS-232 C port
- 9 Connector central compressed air valve
- 10 I/O interface
- 11 Connector warning light
- 12 Connector emergency stop

Fig. 1 Connections

For use in a network the print module is equipped with an I/O interface to start and interrupt the printing and labelling process. It also passes on state information as well as error messages to the control of the network.

2.1 Pin Assignment

The interface has a 25 pin SUB-D connector.

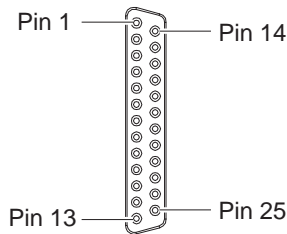

Fig. 2 I/O interface

Pin	Signal	Name	Description		Activation / Active State
			without applicator	with applicator	
1		DREE	-	Print first label in mode "Apply-Print"	Switch on +24 V between Pin 1 and Pin 25
2		VWE	Warning end of labels This signal reports that there is available only a few amount of media.		0 V on Pin 2
3		SUE	-	Lower end position The pad of the applicator is in the labelling position	+24 V on Pin 3
4		PTE	Label transport ON Labels are fed by the print module		+24 V on Pin 4
5		SOE	-	Upper end position The pad of the applicator is in the position where the labels are taken from the printer.	+24 V on Pin 5
6		GND	Ground (0 V) for sensors or trigger switches		
7	-	-	-		-
8		FME	Error "Out of paper" or "Out of ribbon" There is no (more) material (labels or ribbon) in the printer. The operation is stopped and the details and type of error can be read from the display. The last label printed while the error occurred will be repeated.		0 V on Pin 8
9		EDG	Print job available Print jobs are stored in the print module.		+24 V on Pin 9
10		DB	Printer is ready The printer is in Ready state.	Printer and applicator are ready Printer and applicator are in Ready state.	+24 V on Pin 10
11		FEED	Label feed A blank label is forwarded to synchronize the label transport; label feed is proceeded only if no print job is available or an error has occurred		+24 V on Pin 11
12		WDR	Repeat print The last printed label is repeated, counters are not altered in mode "Print-Apply" only		+24 V between Pin 12 and Pin 25
13		START	Print start signal Precondition : The superior control has confirmed with the ETE signal that the previous label has been taken from the peel-off position.	Print/application start signal	+24 V between Pin 13 and Pin 25









Pin	Signal	Name	Description		Activation / Active State
			without applicator	with applicator	
14		PSE	Pause ON/OFF		Pause ON when +24 V between Pin 14 and Pin 25
15		VWF	Warning end of ribbon This signal reports that there is available only a few amount of transfer ribbon.		0 V on Pin 15
16		ETE	Label has been taken Confirmation of the superior control that the label has been taken from the peel-off position. Required for the validity of a new start signal.	-	Switch on +24 V between Pin 16 and Pin 25
17		DAL	Cancel print job The current print job is cancelled and deleted from the print buffer.		Switch on +24 V between Pin 17 and Pin 25
18		RST	Reset		Switch on +24 V between Pin 18 and Pin 25
19		24P	Internal operating voltage +24 V, Si T 100mA for external consumers e.g. sensors, trigger switches		
20		24P_EXT	External operating voltage +24 V		
21		ESP	Label in peel-off position	Applicator is ready for mode "Apply-Print"	+24 V on Pin 21
22		SAA	General error message Error message of both, printer or applicator		0 V on Pin 22
23		STP	Stop signal to interrupt the labelling cycle		Switch on +24 V between Pin 23 and Pin 25
24		EDR	-	Turn label 90° Signal for applicators with selection of label orientation	Switch on +24 V between Pin 24 and Pin 25
25		GND_EXT	Ground of the external 24 V		

Table 1 Pin assignment of the I/O interface

2.2 Circuit Diagram of Inputs and Outputs

Digital Inputs

- conform to IEC/EN 61131-2 (Type 1+3)
- Operating voltage: 24 V DC (18..30 V)
- Switching logic: PNP switching
- Low level „0“: < 5 V DC
- High level „1“: > 15 V DC
- Input current per channel: 4..5 mA (at 24 V DC)
- Galvanic isolation: 3,75 kV
- Reverse polarity protection: yes
- ESD protection: up to 8 kV

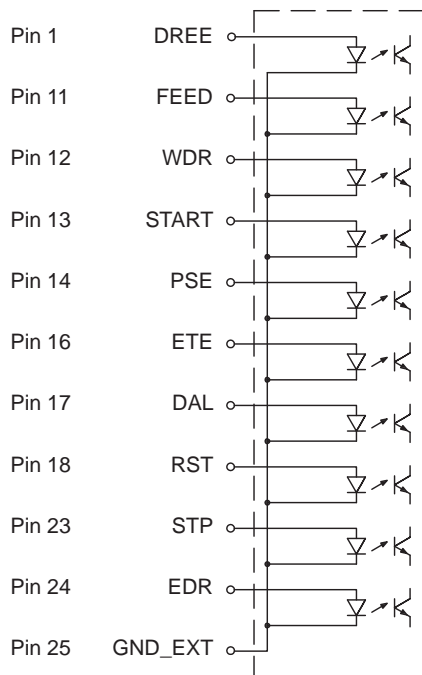

Fig. 3 Connecting inputs

Digital Outputs

- conform to IEC/EN 61131-2
- Operating voltage: 24 V DC (18..30 V)
- Switching logic: PNP switching
- Output current per channel: 700 mA (overload protection)
- Total output current: 700 mA
- Galvanic isolation: 3,75 kV
- Short-circuit protection: yes
- Reverse polarity protection: yes
- ESD protection: up to 8 kV

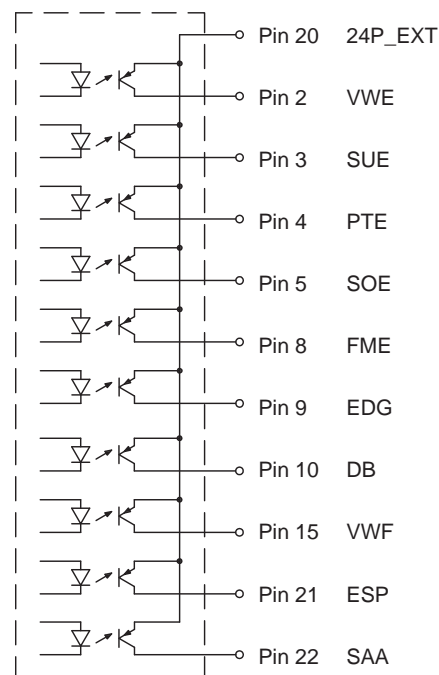

Fig. 4 Connecting outputs



Attention!

Loss of function!

Do not connect Pin 20 with external 0 V (GND).

2.3 External Minimum Circuit

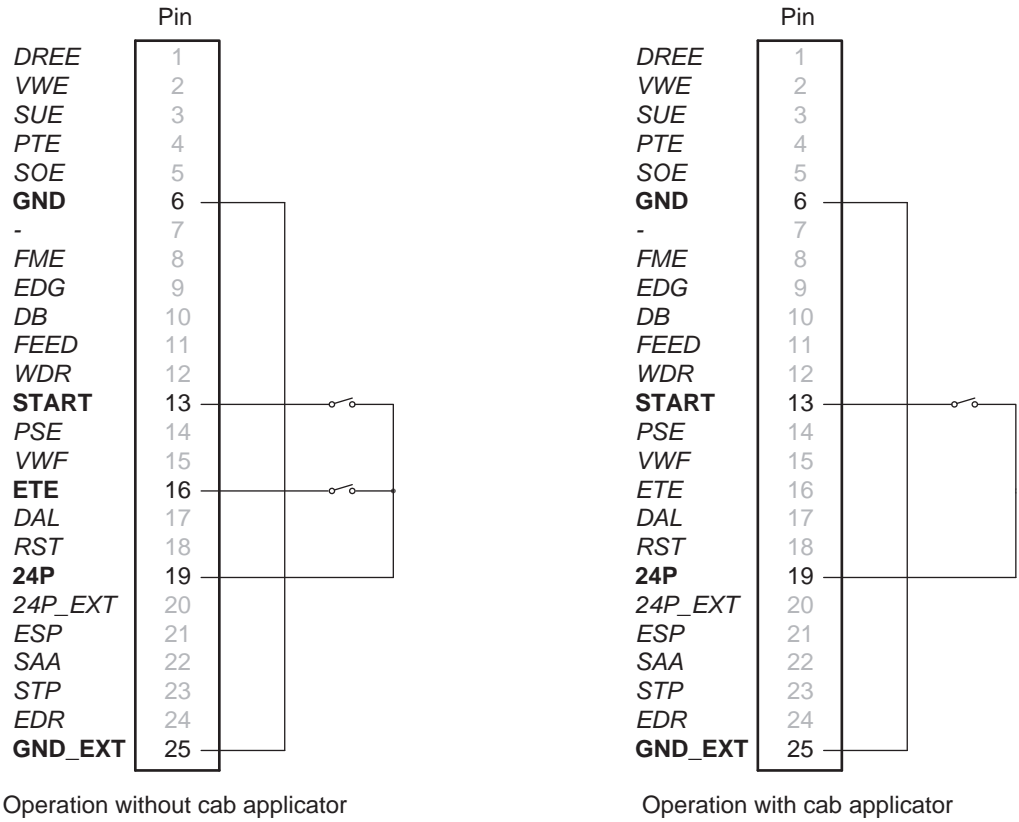

Fig. 5 External minimum circuit of the I/O interface using the internal voltage 24P

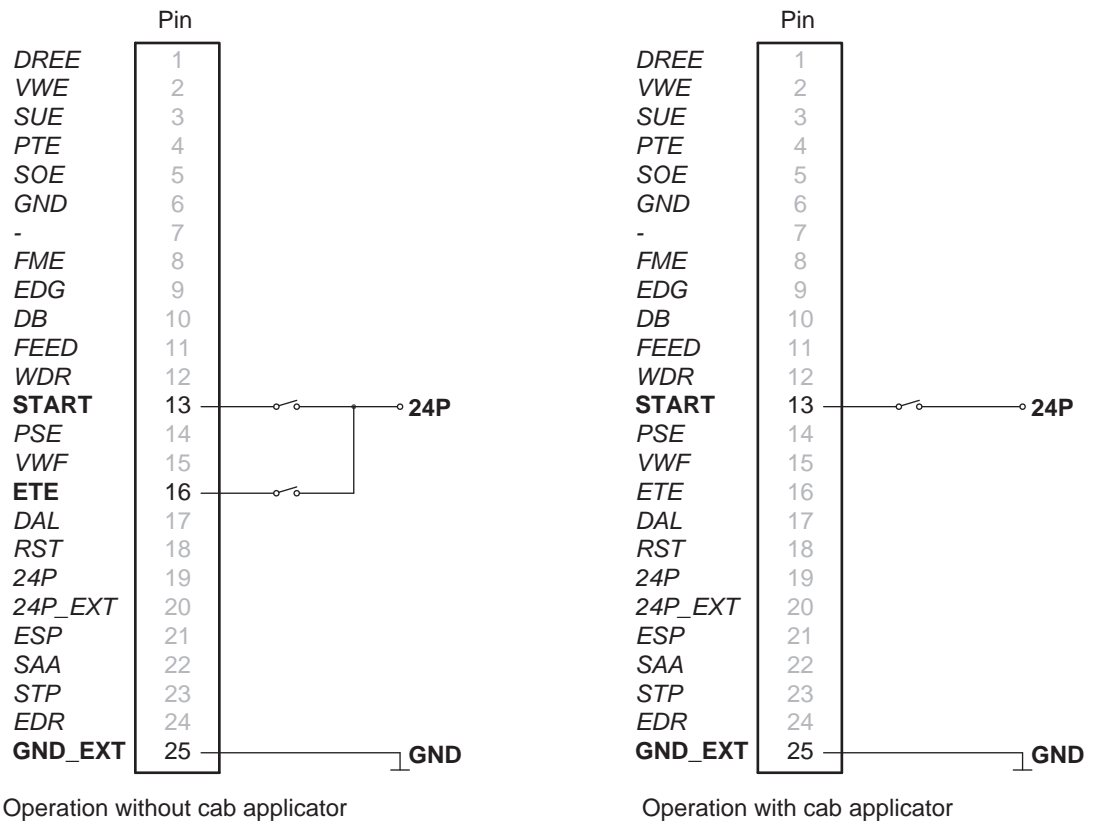

Fig. 6 External minimum circuit of the I/O interface with external voltage supply

2.4 Signal Map

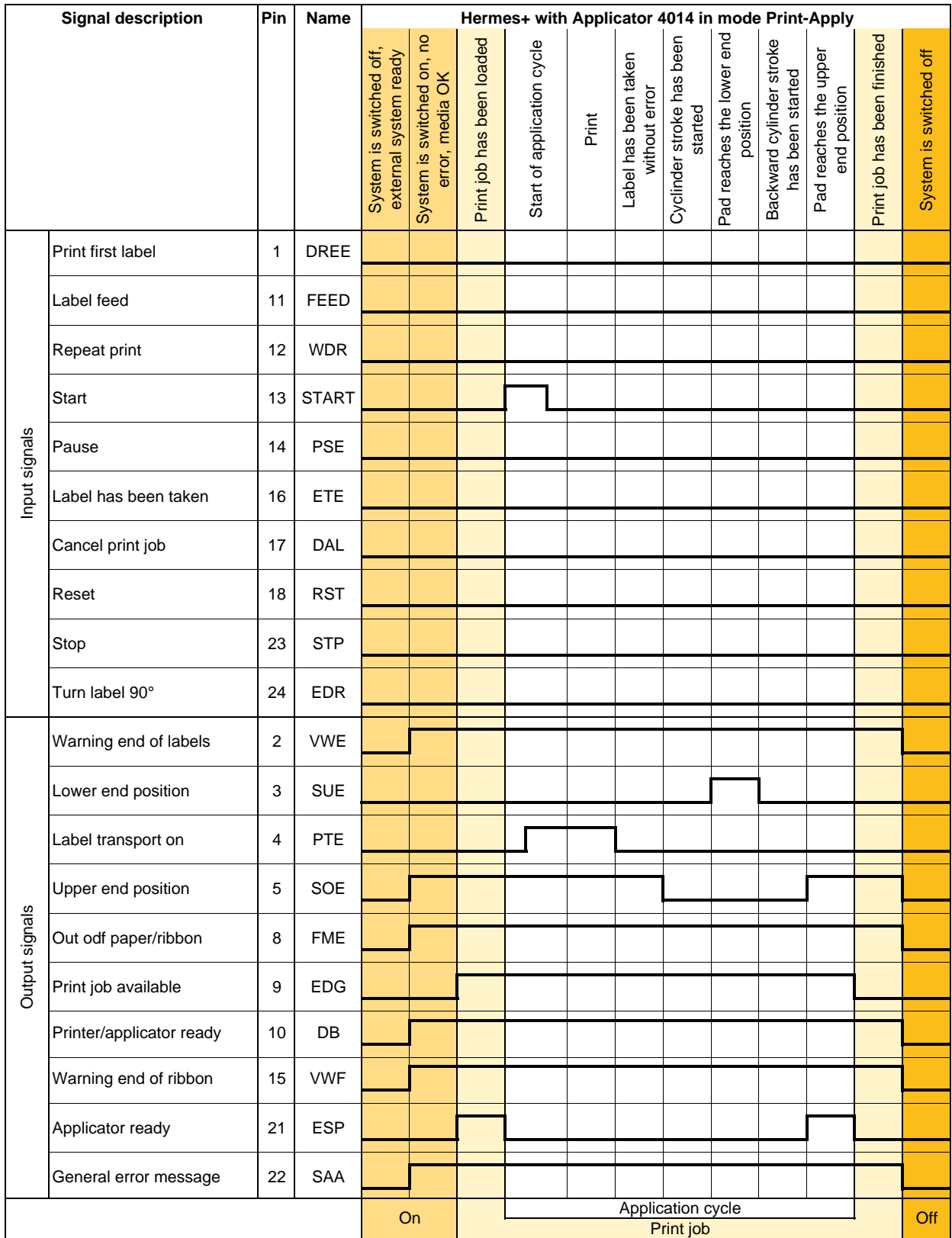

Fig. 7 Signal map Hermes+ with applicator 4014 in mode Print-Apply

2.5 I/O Interface Adapter Hermes A - Hermes+

The I/O interface adapter (Part No. 5961349) provides a 15 pin interface to use existing systems which have used Hermes A labeling systems before.



Attention!

In special applicators signals can be used with other meanings in the firmware.
This can cause functional errors.
In that case contact the producer please.



Notice!

The Hermes A signal "applicator error" is not available.

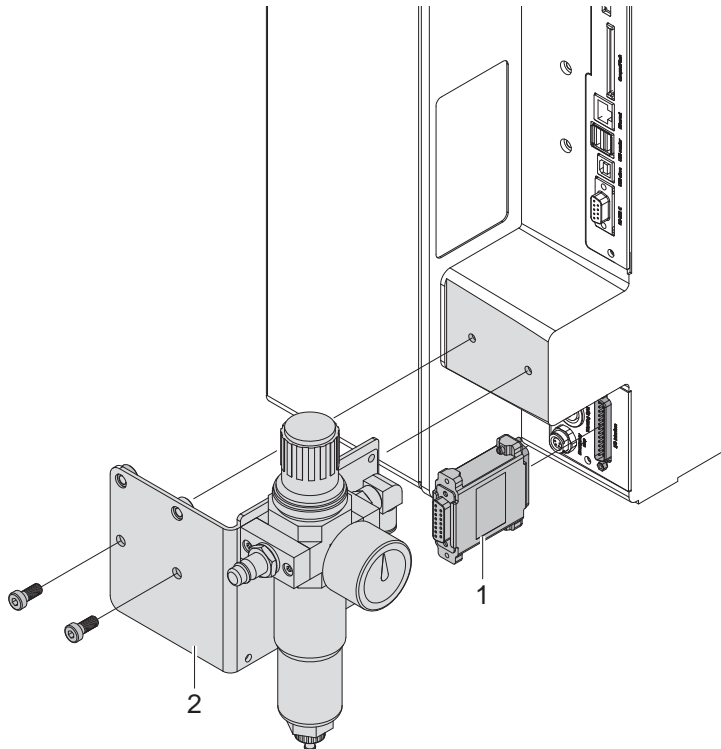

Fig. 8 Mounting the I/O interface adapter



Attention!

Switch off the printer before mounting the adapter.

- ▶ When using a compressed air service unit or a signal lamp remove the mounting bracket (2) from the printer.
- ▶ Mount the interface adapter (1) on the I/O interface of the printer.
- ▶ Connect the cable of the existing system at the interface adapter.
- ▶ Remount the mounting bracket (2) with compressed air service unit or signal lamp on the printer.

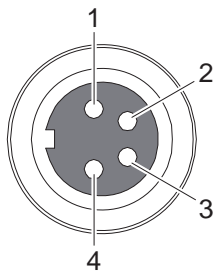

Pin	Direction	Name	Description	Active State
1	⊖ →	24V	Internal operating voltage 24 V	
2	⊖ →	/SGR	Device is switched on	low
3	⊖ →	/SGE	Warning ribbon end or label end is active	low
4	⊖ →	/SRT	Error	low

Fig. 9 Connector warning light Table 2 Pin assignment connector warning light

4 Connector Emergency Stop

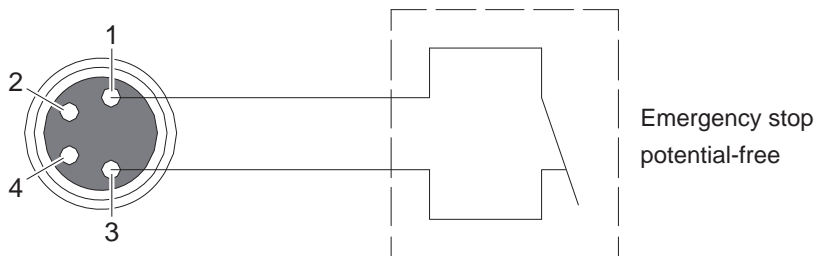

Fig. 10 Connector emergency stop

With an emergency stop connected to the 4-pin socket the compressed air in the labelling system can be switched off by a central valve.

5 Connector Central Compressed Air Valve

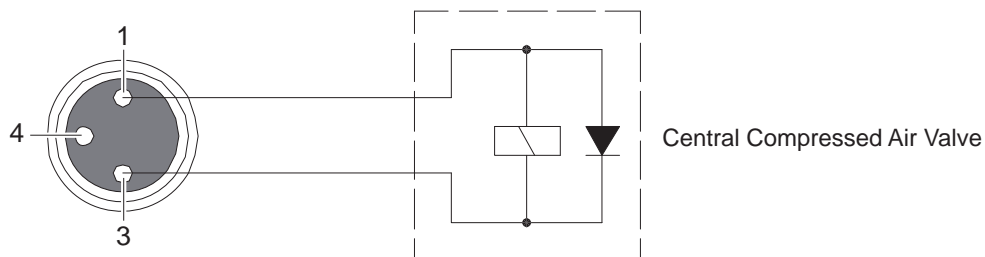

Fig. 11 Connector central compressed air valve

With a central compressed air valve connected to the 3-pin socket the compressed air in the labelling system can be switched off by an emergency stop.



Attention!

For using the central compressed air valve the I/O interface must be connected to 24 V at Pin 20 and to GND at Pin 25.