



Battery Pack

HS/VS 120

Made in Germany

Type	
Battery Pack	HS/VS 120

Edition: 03/2016 - **Part.-No.** 9009644

Copyright

This documentation as well as translation hereof are property of cab Produkttechnik GmbH & Co. KG.

The replication, conversion, duplication or divulgement of the whole manual or parts of it for other intentions than its original intended purpose demand the previous written authorization by cab.

Editor

Regarding questions or comments please contact cab Produkttechnik GmbH & Co. KG.

Topicality

Due to the constant further development of our products discrepancies between documentation and product can occur.

Please check www.cab.de for the latest update.

Terms and conditions

Deliveries and performances are effected under the General conditions of sale of cab.

Table of Contents

1	Introduction	3
1.1	Product Description	3
1.2	Instructions	3
1.3	Intended Use	4
1.4	Safety Instructions	4
1.5	Environment.....	5
1.6	Technical Data	5
2	Installation	6
2.1	Contents of Delivery	6
2.2	Mounting	6
2.3	Connecting.....	7
3	Operation	8
3.1	Switching on	8
3.2	Display LED	8
4	Charging	9
5	Licences	10
5.1	Reference to the EU Declaration of Conformity	10
5.2	FCC	10

Germany

cab Produkttechnik
GmbH & Co KG
Postfach 1904
D-76007 Karlsruhe
Wilhelm-Schickard-Str. 14
D-76131 Karlsruhe

Telefon +49 721 6626-0
Telefax +49 721 6626-249

www.cab.de
info@cab.de

France

cab technologies s.a.r.l.
F-67350 Niedermodern
Téléphone +33 388 722 501
www.cab.de/fr
info.fr@cab.de

USA

cab Technology Inc.
Tyngsboro MA, 01879
Phone +1 978 649 0293
www.cab.de/us
info.us@cab.de

Asia 亚洲

cab Technology Co., Ltd.
希愛比科技股份有限公司
Junghe, Taipei, Taiwan
Phone +886 2 8227 3966
www.cab.de/tw
info.asia@cab.de

China 中国

cab (Shanghai)Trading Co., Ltd.
锐博(上海)贸易有限公司
Phone +86 21 6236-3161
www.cab.de/cn
info.cn@cab.de

1.1 Product Description

The Battery Packs are designed as power supplies for the cab label dispenser HS/VS.

1.2 Instructions

Important information and instructions in this documentation are designated as follows:



Danger!

Draws your attention to an exceptionally grave, impending danger to your health or life.



Warning!

Indicates a hazardous situation that could lead to injuries or material damage.



Attention!

Draws attention to possible dangers, material damage or loss of quality.



Notice!

Gives you tips. They make a working sequence easier or draw attention to important working processes.



Environment!

Gives you tips on protecting the environment.



Handling instruction



Reference to section, position, illustration number or document.



Option (accessories, peripheral equipment, special fittings).

Time Information in the display.

1.3 Intended Use

- The Battery Packs are exclusively designed as power supplies for the cab label dispenser HS/VS 120. Any other use or use going beyond this shall be regarded as improper use. The manufacturer/supplier shall not be liable for damage resulting from unauthorized use; the user shall bear the risk alone.
- The device is manufactured in accordance with the current technological status and the recognized safety rules. However, danger to the life and limb of the user or third parties and/or damage to the device and other tangible assets can arise during use.
- The device may only be used for its intended purpose and if it is in perfect working order, and it must be used with regard to safety and dangers as stated in the operating manual.
- Usage for the intended purpose also includes complying with the operating manual, including the manufacturer's maintenance recommendations and specifications.

**Notice!**

The complete documentation can also currently be found in the Internet.

1.4 Safety Instructions

- The device is configured for voltages of 100 to 240 V AC. It only has to be plugged into a grounded socket.
- Only connect the device to other devices which have a protective low voltage.
- The device may only be used in a dry environment, do not expose it to moisture (sprays of water, mists, etc.).
- Do not use the device in an explosive atmosphere.
- Do not use the device close to high-voltage power lines.
- Perform only those actions described in this operating manual. Work going beyond this may only be performed by trained personnel or service technicians.
- Unauthorized interference with electronic modules or their software can cause malfunctions.
- Other unauthorized work on or modifications to the device can also endanger operational safety.
- Always have service work done in a qualified workshop, where the personnel have the technical knowledge and tools required to do the necessary work.
- There are various warning stickers on the device. They draw your attention to dangers. Warning stickers must therefore not be removed, as then you and other people cannot be aware of dangers and may be injured.

**Danger!**

Danger to life and limb from power supply.

- ▶ Do not open the device casing.

**Warning!**

This is a class A product. In a domestic environment this product may cause radio interference in which case the user may be required to take adequate measures.

1.5 Environment



Obsolete devices contain valuable recyclable materials that should be sent for recycling.

- ▶ Send to suitable collection points, separately from residual waste.

The modular construction of the HS/VS enables it to be easily disassembled into its component parts.

- ▶ Send the parts for recycling.



The Battery Pack is equipped with a NiMH batteries.

- ▶ Take old batteries to collection boxes in shops or public waste disposal centers..

1.6 Technical Data

	Battery Pack HS/VS 120
Battery	NiMH (Nickel-Metal Hydride)
Nominal voltage	18 V
Nominal current	2,5 A (max. 30 A for 30 ms.)
Capacity	2,1 Ah
Charging time	max. 2 h
Charging cycles	> 500
Power supply	100 – 240 VAC 50/60 Hz
Temperature/ Humidity	
Operation:	+5 – 40°C/10 – 85 % not condensing
Storage:	+0 – 60°C/20 – 80 % not condensing
Transport:	-25 – 60°C/20 – 80 % not condensing

2.1 Contents of Delivery

- Battery Pack
- Power Cable
- Operator's Manual



Notice!

Please keep the original packaging in case the battery pack must be returned.

2.2 Mounting

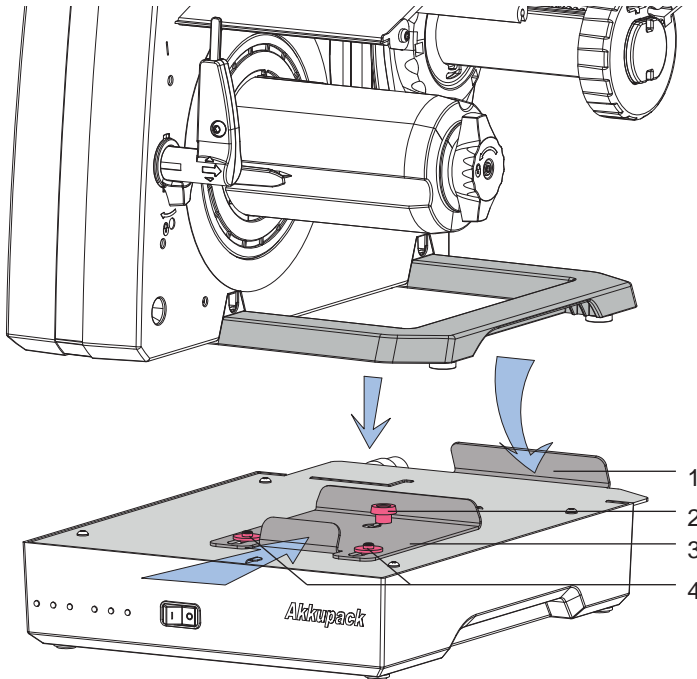

Fig. 1 Mounting

- ▶ Set up the battery pack on a level surface.
- ▶ Loosen knurled screw (2).
- ▶ Pull the fixing plate (3) to the front.
- ▶ Push the baseplate of the HS/VS into the rear clip (1) of the battery pack.
- ▶ Slide the fixing plate (3) to the rear side .
- ▶ Tighten screw (2).

2.3 Connecting

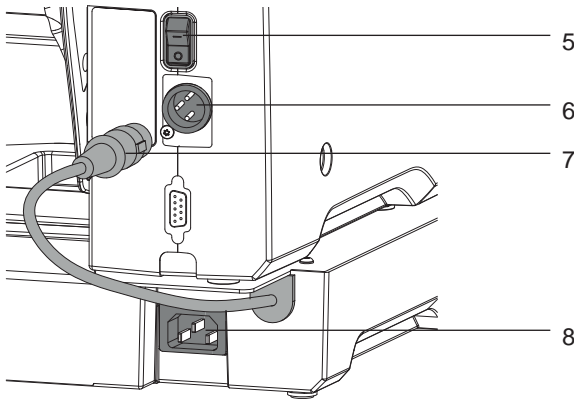

Fig. 2 Connecting



Notice!

- ▶ **Charge the battery pack completely prior to the first use !**
 - ▷ **4. Charging**
- ▶ Ensure that battery pack and HS/VS are switched off.
- ▶ Connect cable (7) to the connector of the HS/VS (6).

3.1 Switching on

- ▶ Switch on the power switches at battery pack front side and HS/VS (5).
- The HS/VS can be operated in the same way as a HS/VS with mains supply.
- In battery operation mode the charge control LED L1 - L3 are switched off.
- Depending on the charge level the matching charge level LED L4 - L6 is blinking.

3.2 Display LED

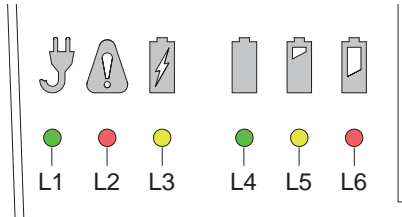

Fig. 3 Display LED

Charge control		
L1	green	Battery pack is connected to mains
L2	red	Charging error
L3	yellow	Battery is charged
Charge level		
L4	green	Capacity 70 - 100%
L5	yellow	Capacity 30 - 70 %
L6	red	Capacity < 30%



Attention!

Risk of premature loss of performance!

- ▶ **Charge the battery pack at least every six months also if it is not used.**



Notice!

During the battery charging the HS/VS can be used.

- ▶ Plug the power cable into the power connection socket (8, Fig. 2).
- ▶ Plug the power cable into a grounded socket.
- The charging begins.
LED L4 - L6 are switched off. LED L1 and L3 are switched on.
- When the yellow LED L3 is switched off, the charging process is finished.
- ▶ If an charging error occurs (LED L2 on) switch off and on the battery pack.



Notice!

NiMH batteries show a lazy battery effect.

The batteries gradually lose their maximum energy capacity if they are repeatedly recharged after being only partially discharged.

The effect can be eliminated by approximately five complete loading and unloading cycles again.

5.1 Reference to the EU Declaration of Conformity

The battery packs for HS/VS 120 comply with the relevant fundamental regulations of the EU Rules for Safety and Health:

- Directive 2014/35/EU relating to electrical equipment designed for use within certain voltage limits
- Directive 2014/30/EU relating to electromagnetic compatibility
- Directive 2011/65/EU on the restriction of the use of certain hazardous substances in electrical and electronic equipment

EU Declaration of Conformity

▷ <https://www.cab.de/media/pushfile.cfm?file=2704> 



5.2 FCC

NOTE : This equipment has been tested and found to comply with the limits for a Class A digital device, pursuant to Part 15 of the FCC Rules. These limits are designed to provide reasonable protection against harmful interference when the equipment is operated in a commercial environment. The equipment generates, uses, and can radiate radio frequency and, if not installed and used in accordance with the instruction manual, may cause harmful interference to radio communications. Operation of this equipment in a residential area is likely to cause harmful interference in which case the user may be required to correct the interference at his own expense.