

Operating Instructions

Label File Selection Box - Input/Output Box (Part No. 5944999)

Edition: 11/2013 · Part No. 9009597

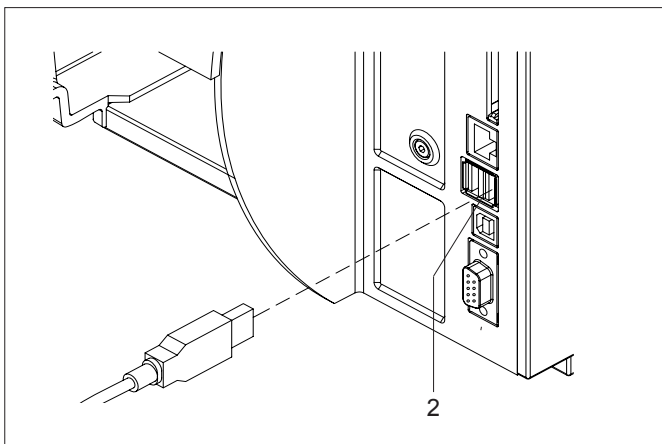
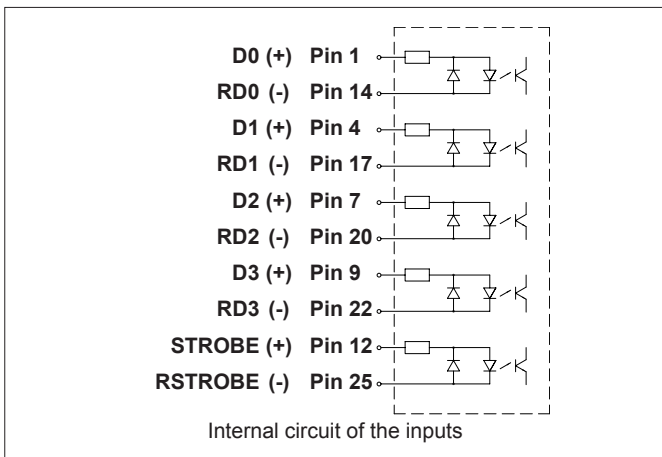
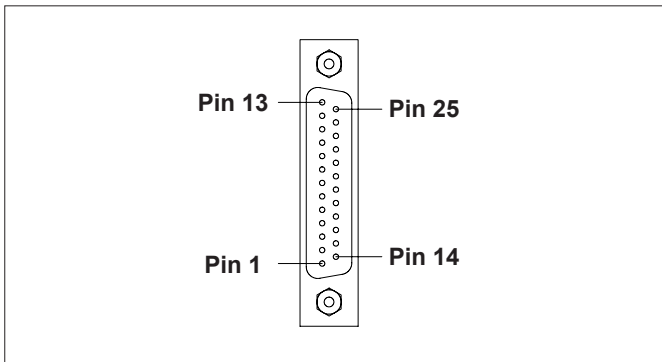
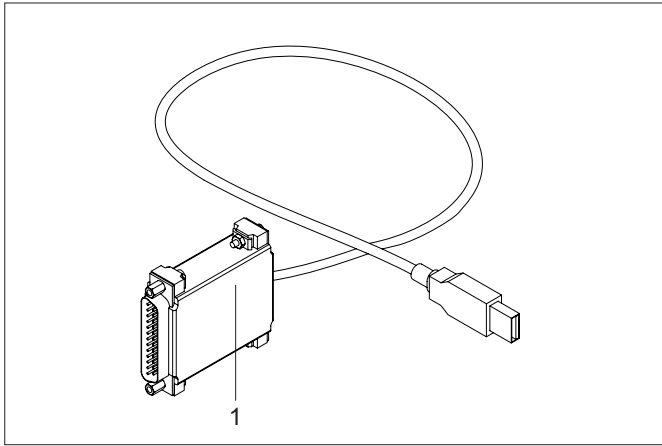

The box can be operated in two basic functions depending on the use of a jumper :

- without** jumper Pin 11 - Pin 13 : **Label file selection box**
- with** jumper Pin 11 - Pin 13 : **Input/Output box**

Label File Selection Box

Function

With the label file selection box 16 different print jobs can be selected via PLC interface. The corresponding J-Script data must be filed on a memory medium in the printer.

System Requirements

Printer of the A+, MACH4, Hermes+, PX or EOS Series



To operate the label file selection box the printer firmware version 3.03 (for EOS 4.05) or higher is needed !

Pin Assignment of the 25-pin Plug

Pin	Signal	Pin	Reverse line	Direction	Function
1	D0	14	RD0	Input	Selection value 2 ⁰
4	D1	17	RD1	Input	Selection value 2 ¹
7	D2	20	RD2	Input	Selection value 2 ²
9	D3	22	RD3	Input	Selection value 2 ³
12	STROBE	25	RSTROBE	Input	Validity signal
11	MODE	13	GND	Do not connect with each other !!!	

To operate the box as label file selection box Pin 11 and 13 must not be connected with each other.

Each input signal D0-D3, STROBE has a separate reverse line. The particular signal is active when between the signal pin and the respective reverse line +24 V is applied with (+) at the signal.

The circuits of the inputs cause a potential separation.

Operation

- ▶ Store up to 16 label files named E16.LBL up to E31.LBL in the path \LABELS of the memory medium.
- ▶ Insert the memory medium in the printer.
- ▶ Connect the box (1) to a USB master interface (2) of the printer.
- ▶ Connect the 25-pin SUB-D plug of the box (1) to the PLC interface using a suitable cable.
- ▶ Select the designated file Ex via PLC by activating the binary-coded selection signals:
 $x = 16 + D3 \cdot 2^3 + D2 \cdot 2^2 + D1 \cdot 2^1 + D0 \cdot 2^0$
 Example : With D3 and D1 the file E26.LBL is selected.
- ▶ Confirm the selection via PLC by activating the signal STROBE for at least 50 ms.

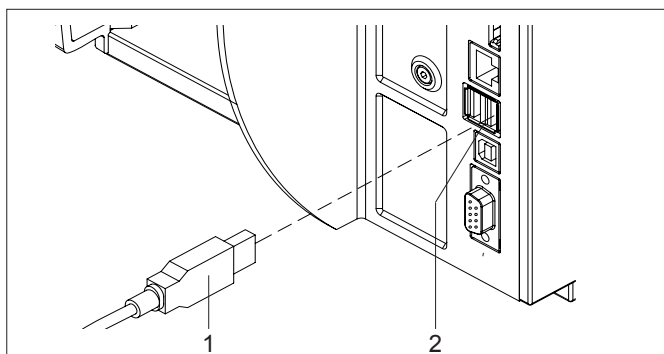
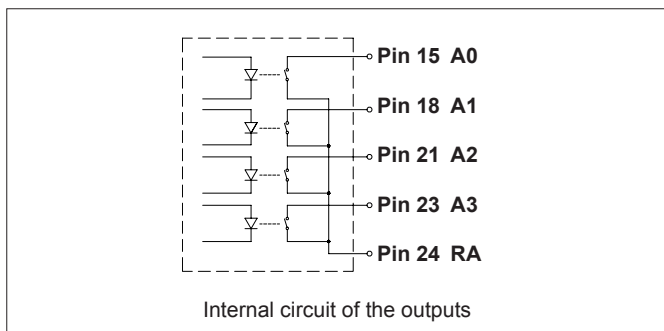
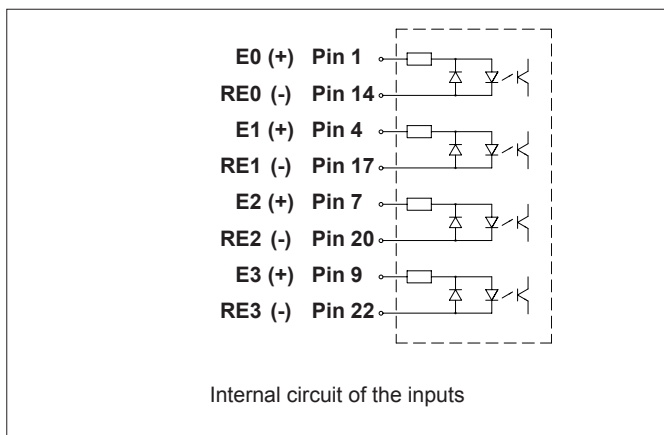
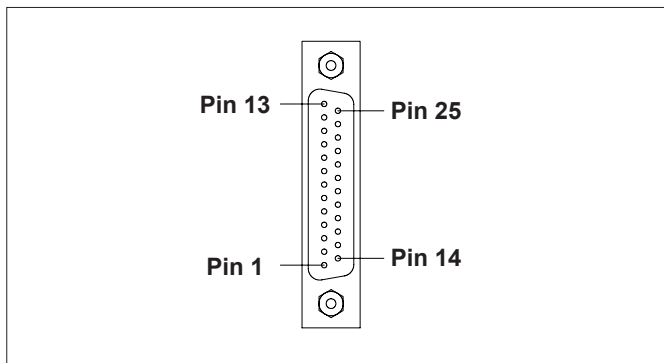

Input/Output Box

Function

The input/output box allows to realize simple PLC procedures. Using abc-programming the printer can read four inputs and set four outputs. That allows the communication with other devices. In the programming a separate bit is assigned to each input and output (▷ Programming Manual).

The abc-programming must be especially designed for the particular application.

System Requirements

Printer of the A+, MACH4, Hermes+, PX or EOS Series



To operate the input/output box the printer firmware version 3.08 (for EOS 4.05) or higher is needed !

Pin Assignment of the 25-pin Plug

Pin	Signal	Pin	Reverse line	Direction	Function
1	E0	14	RE0	Input	Input bit 0
4	E1	17	RE1	Input	Input bit 1
7	E2	20	RE2	Input	Input bit 2
9	E3	22	RE3	Input	Input bit 3
15	A0	24	RA	Output	Output bit 0
18	A1			Output	Output bit 1
21	A2			Output	Output bit 2
23	A3			Output	Output bit 3
11	MODE	13	GND	Jumper required	

To operate the box as input/output box Pin 11 and 13 must be connected with each other.

Each input signal E0-E3, STROBE has a separate reverse line. The particular signal is active when between the signal pin and the respective reverse line +24 V is applied with (+) at the signal Ex.

All output signals A0-A3 have the common reverse line RA. When an output bit is set to "high" there is a low-resistance connection between Ax and RA.

The inputs and output circuits cause a potential separation.

Operation

- ▶ Connect the box (1) to a USB master interface (2) of the printer.
- ▶ Connect the 25-pin SUB-D plug of the box (1) to the external device using a suitable cable.
- ▶ Send a print job containing an abc-program to control the external device.

Germany

cab Produkttechnik
GmbH & Co KG
Postfach 1904
D-76007 Karlsruhe
Wilhelm-Schickard-Str. 14
D-76131 Karlsruhe
Telefon +49 721 6626-0
Telefax +49 721 6626-249
www.cab.de
info@cab.de

France

cab technologies s.a.r.l.
F-67350 Niedermodern
Téléphone +33 388 722 501
www.cab.de/fr
info.fr@cab.de

USA

cab Technology Inc.
Tyngsboro MA, 01879
Phone +1 978 649 0293
www.cab.de/us
info.us@cab.de

South Africa

cab Technology (Pty.) Ltd.
2125 Randburg
Phone +27 11-886-3580
www.cab.de/za
info.za@cab.de

Asia 亚洲

cab Technology Co., Ltd.
希愛比科技股份有限公司
Junghe, Taipei, Taiwan
Phone +886 2 8227 3966
www.cab.de/tw
info.asia@cab.de

China 中国

cab (Shanghai) Trading Co., Ltd.
铠博(上海)贸易有限公司
Phone +86 21 6236-3161
www.cab.de/cn
info.cn@cab.de

Representatives in other countries on request